

UNITEDHEALTH GROUP



Optum

Admin Interiors Signage Standards

March 2024

Ver. 1.0.7



Suite Entrance Signage Standards

1. Does the building have a specific criteria to follow for entrance signage?

Yes - Follow Building Standard Sign Criteria Details.

No - What is the entrance layout?

WOODEN DOOR WITH SIDELIGHT

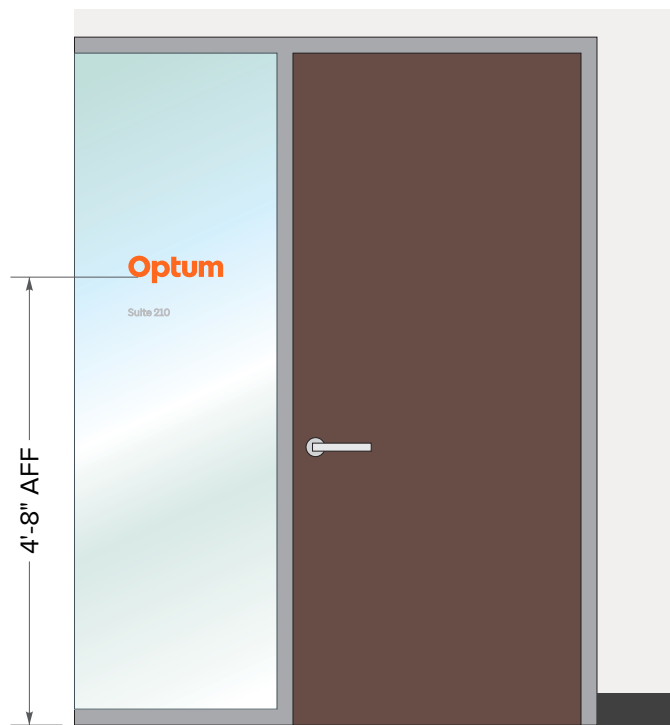

SCALE: 1/2" = 1'-0"

White Vinyl with suite number applied to side light, first surface.

WOODEN DOOR WITHOUT SIDELIGHT

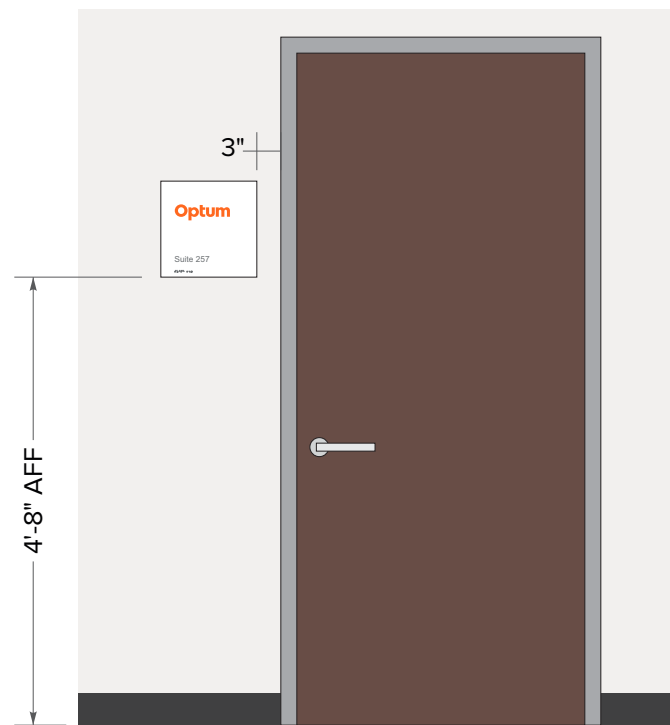

SCALE: 1/2" = 1'-0"

1/8" Acrylic wall plaque decorated with vinyl.

GLASS DOOR WITH SIDELIGHT

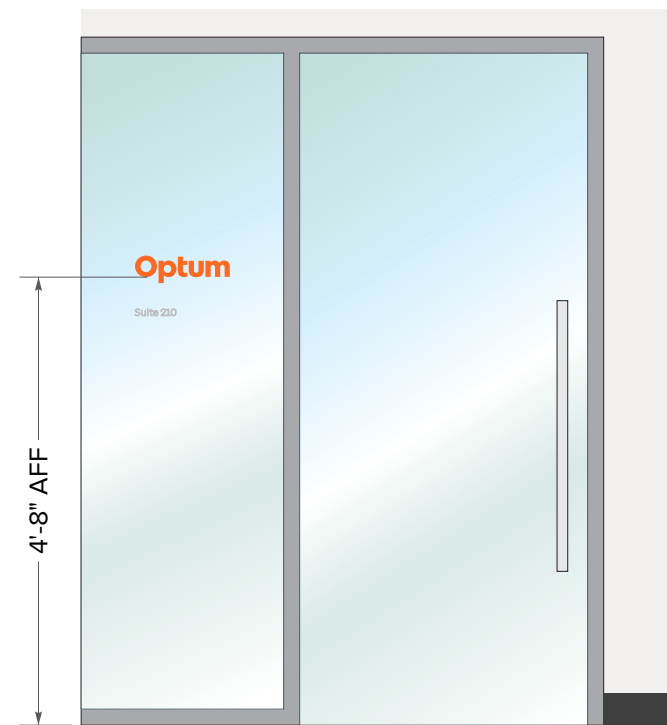

SCALE: 1/2" = 1'-0"

White Vinyl with suite number applied to side light, first surface.

DOUBLE GLASS DOOR

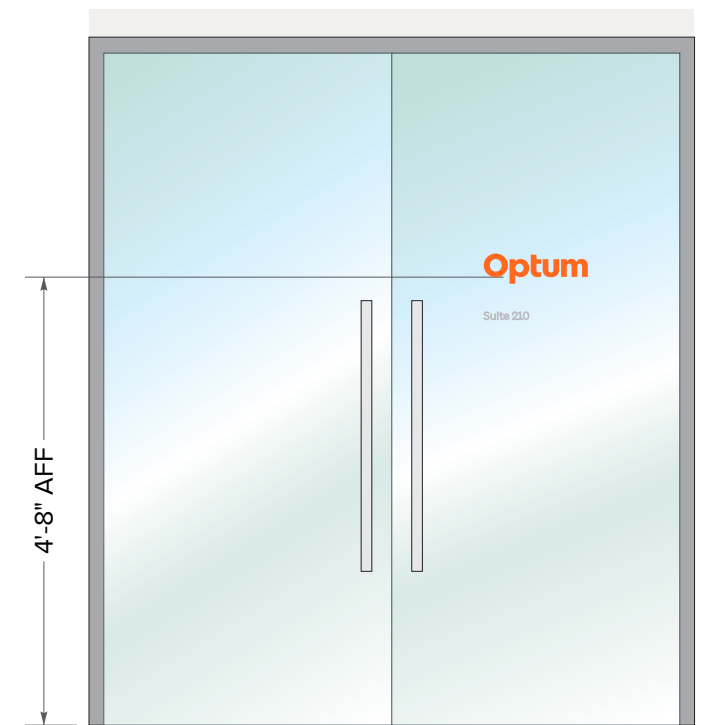

SCALE: 1/2" = 1'-0"

White Vinyl with suite number applied to right door, first surface.

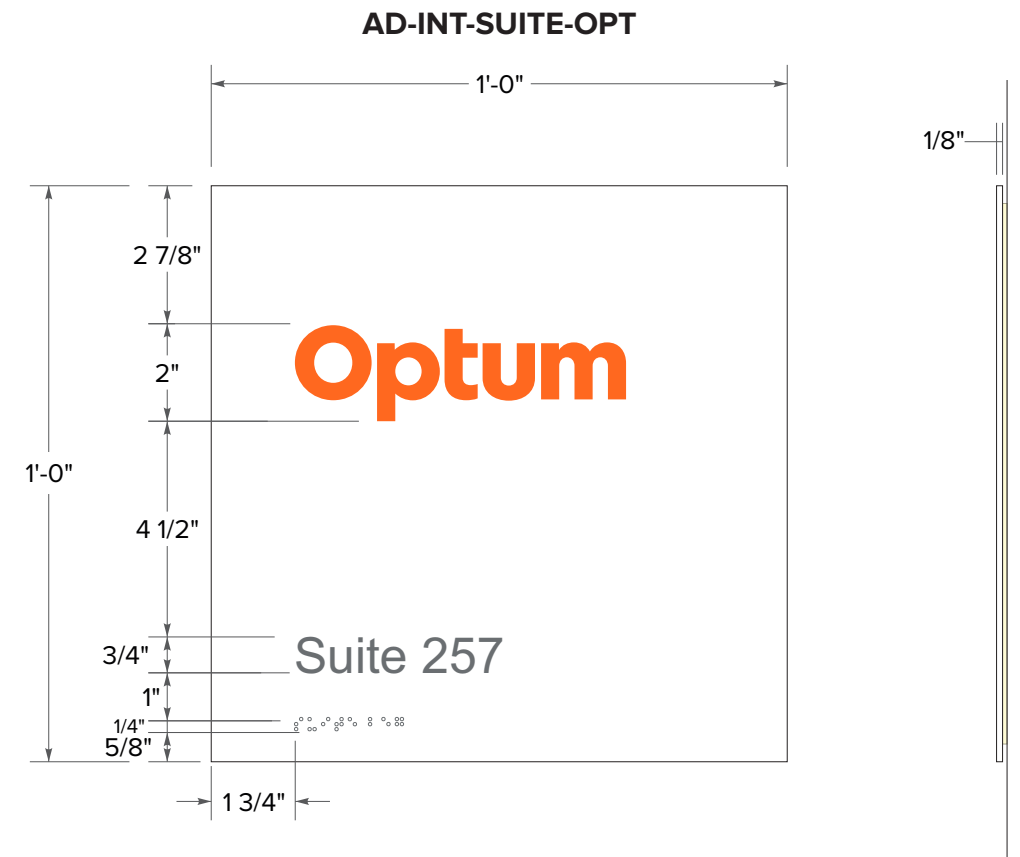
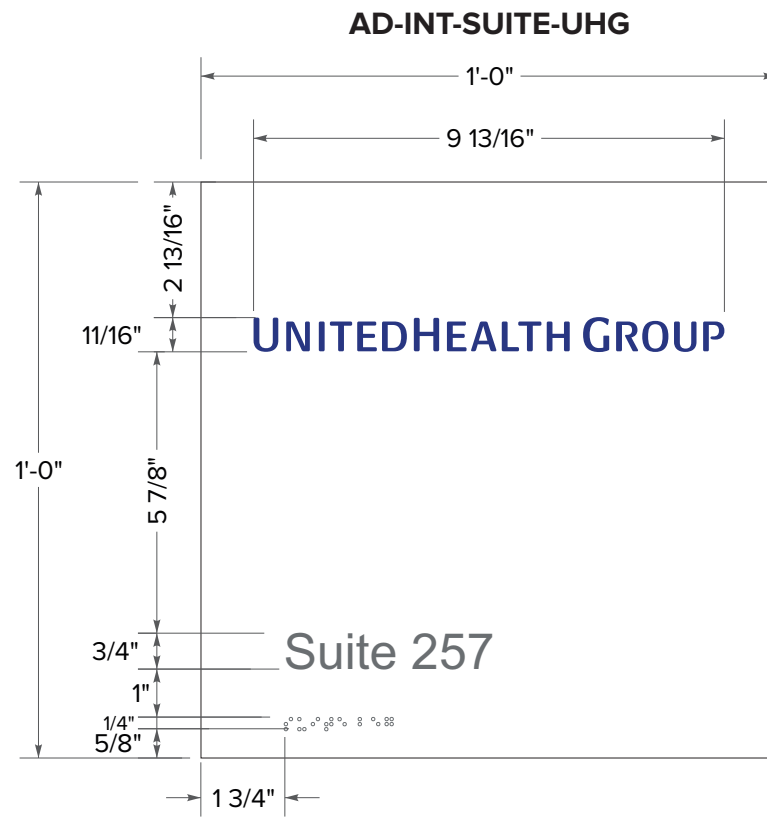
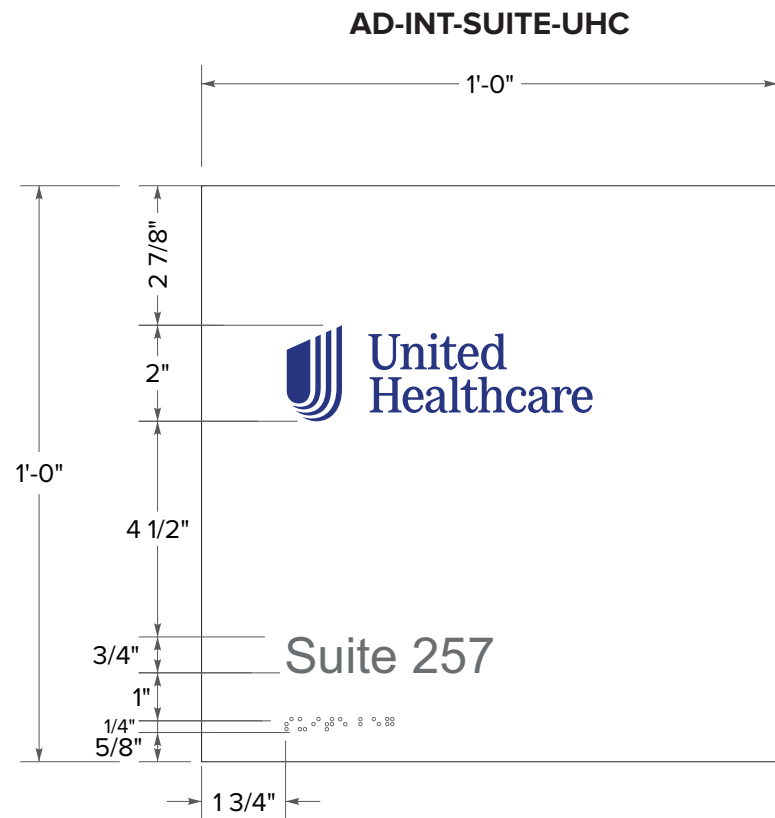

SCALE | 1:4

COLOR/ MATERIAL SPECIFICATIONS

- PANEL: 1/8" thick acrylic surface painted Akzo Nobel 493-A1 White, Matte finish
- COPY: Surface applied 3M #7725-41 Dark Grey vinyl;
 - UHC / UHG Logo to be 3M #7725-37 Sapphire Blue vinyl
 - Optum Logo to be 3M #180mc-3289 Opaque Orange vinyl

FONT: Arial Regular

BRAILLE: Grade II - Clear Braille Rasters

INSTALL: Install flush to wall with silicone and 3M 1/8" White Double-Faced Foam tape

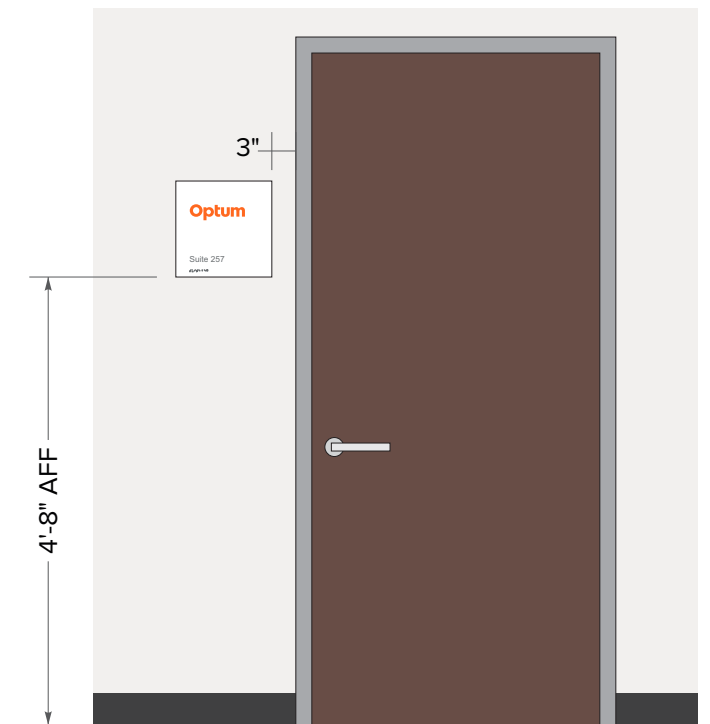

WALL MOUNT
SCALE: 1/2" = 1'-0"

Privacy Graphic approved applications:
 Suite Entrance Doors
 (Applied to outside of window area of rooms)

Signage should be provided for consistency to match other suite signage as the preference for design.

Suite information to be included with door vinyl only if applicable.

COLOR/MATERIAL SPECIFICATIONS

- COPY: Surface applied 3M 180mc-10 Opaque White
- UHC / UHG Logo to be 3M #7725-37 Sapphire Blue vinyl
- Optum Logo to be 3M #180mc-3289 Opaque Orange vinyl

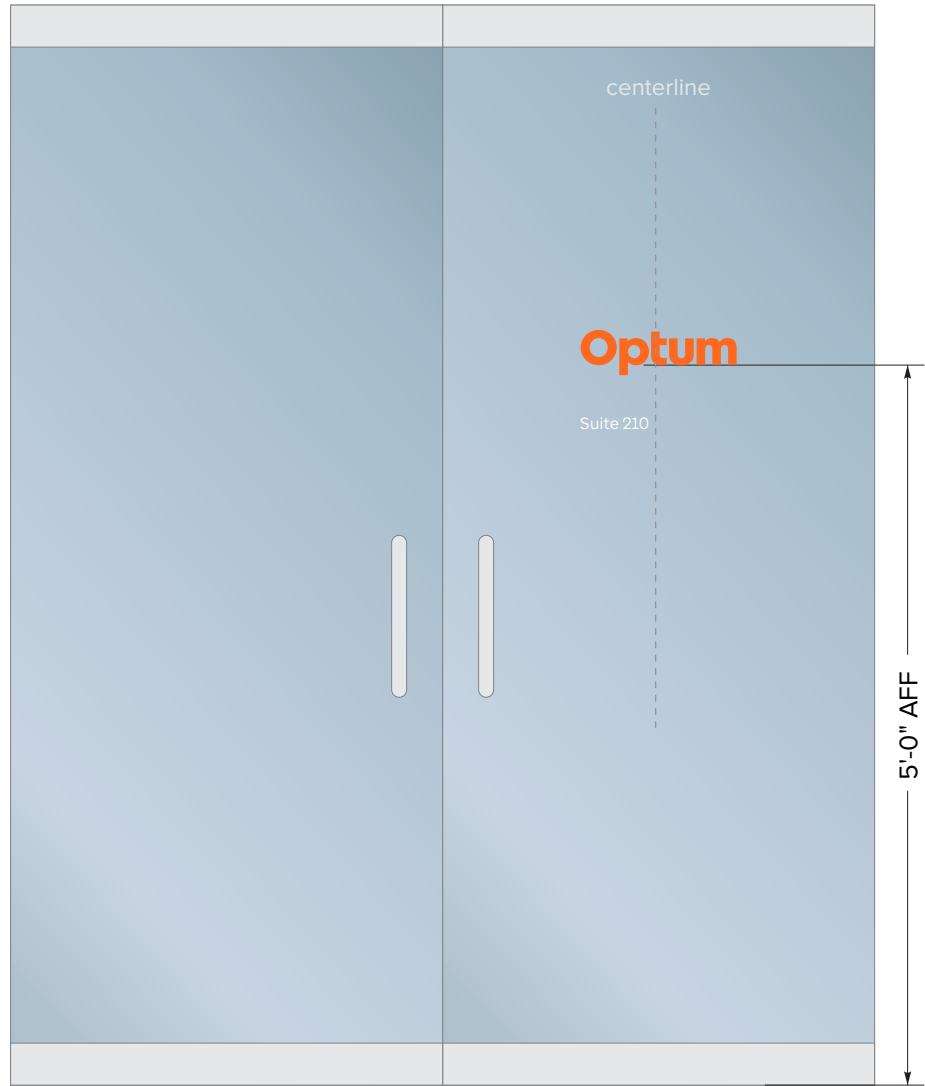

scale: 3/4" = 1'-0"

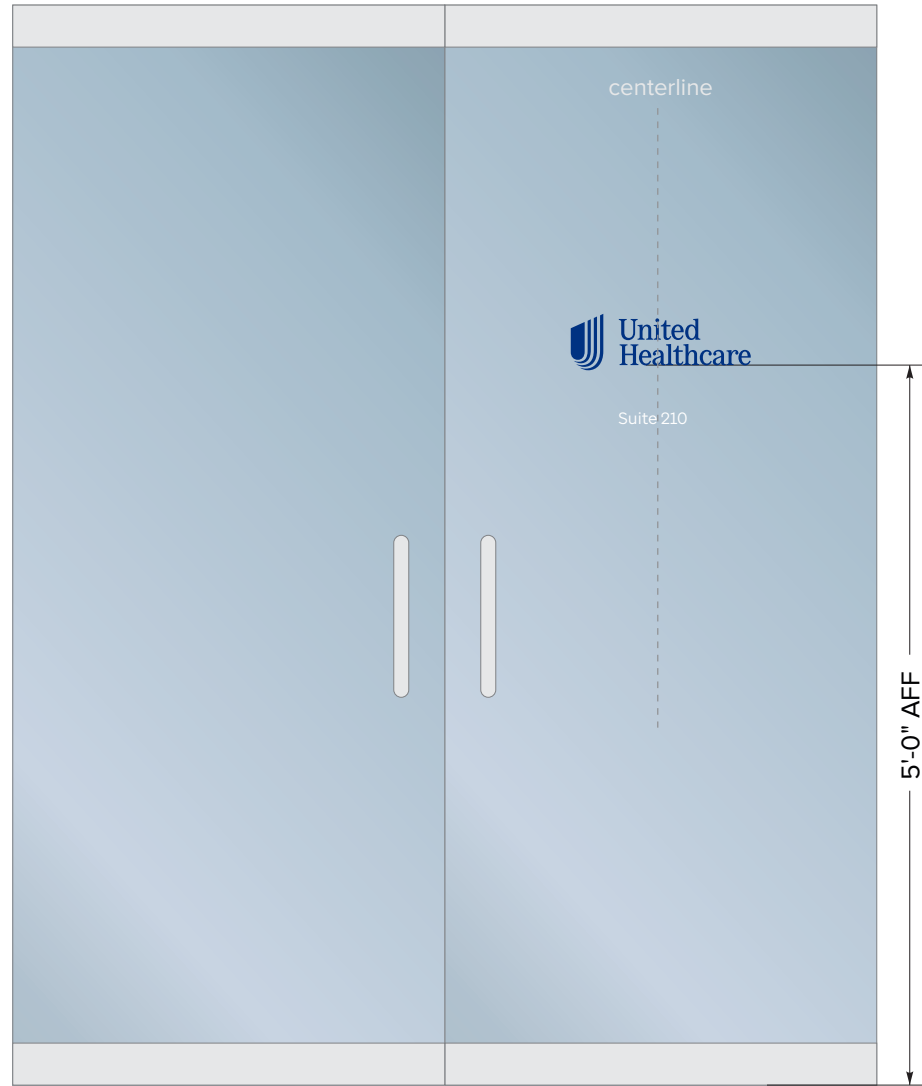

scale: 3/4" = 1'-0"

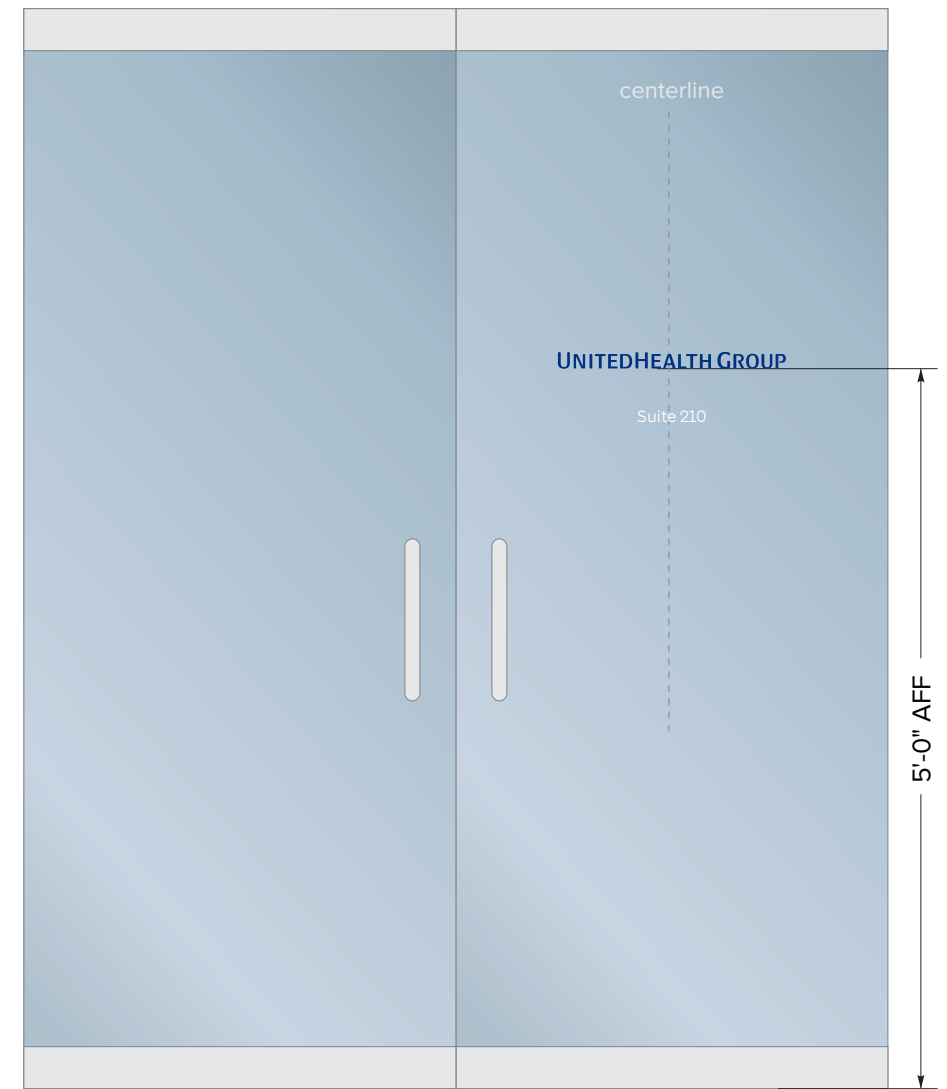

scale: 3/4" = 1'-0"

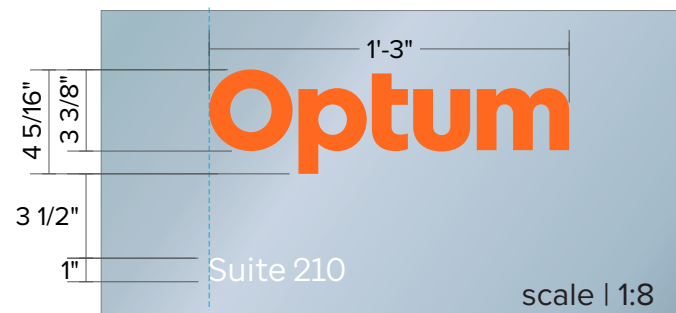

scale | 1:8



scale | 1:8

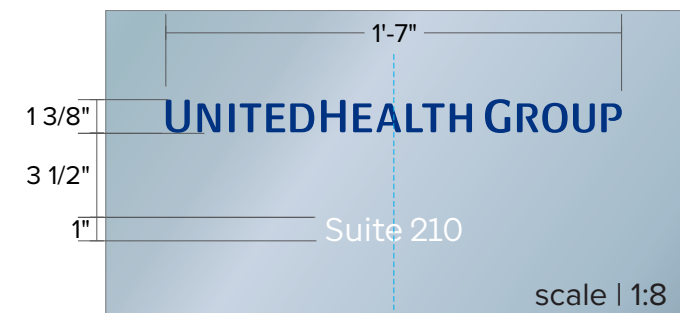

scale | 1:8

Privacy Graphic approved applications:
 Suite Entrance Doors
 (Applied to outside of window area of rooms)

Suite information to be included with door vinyl only if applicable.

OPTION 1

Preference is the top stacked business name is the majority tenant.

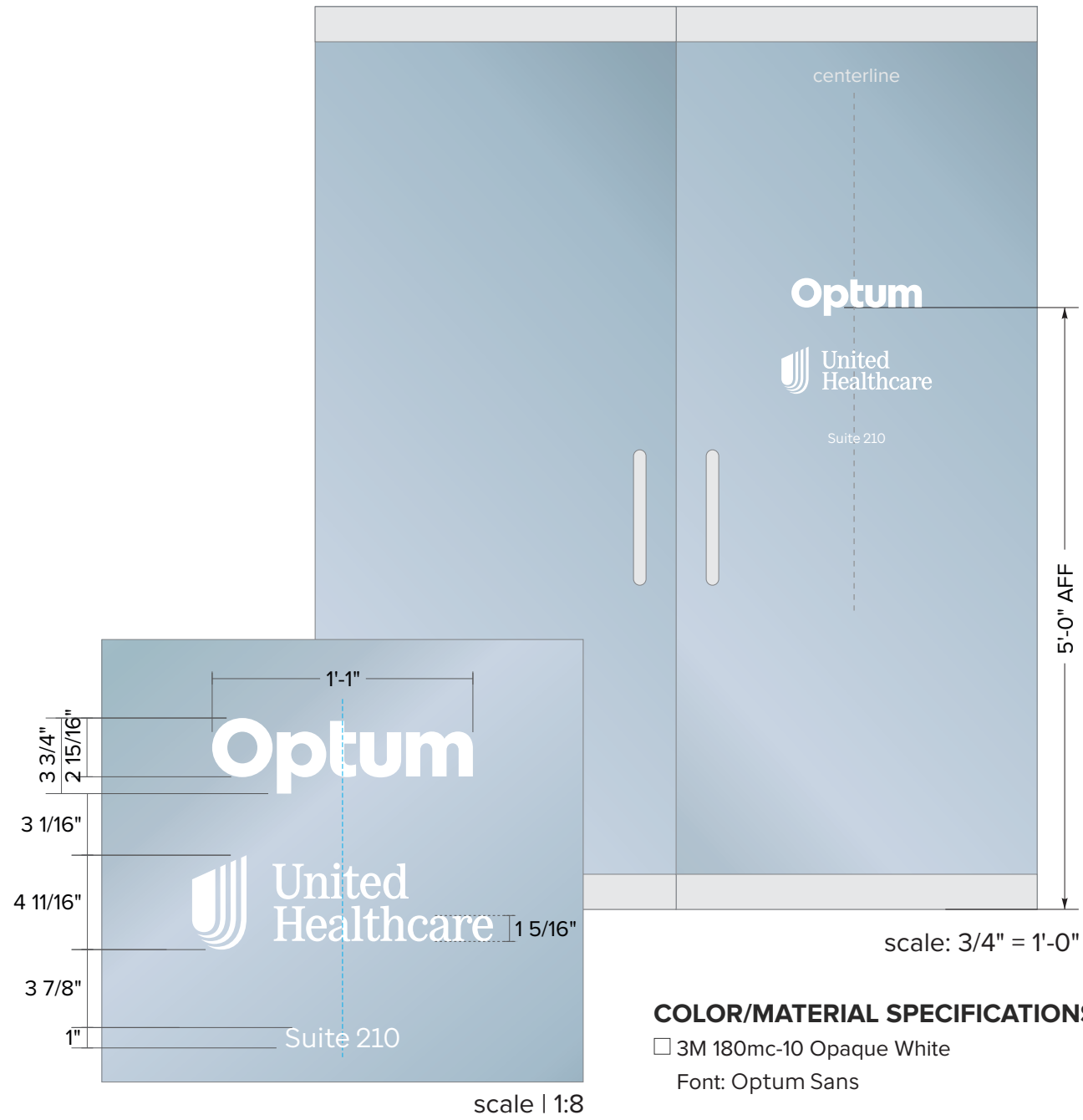

OPTION 2

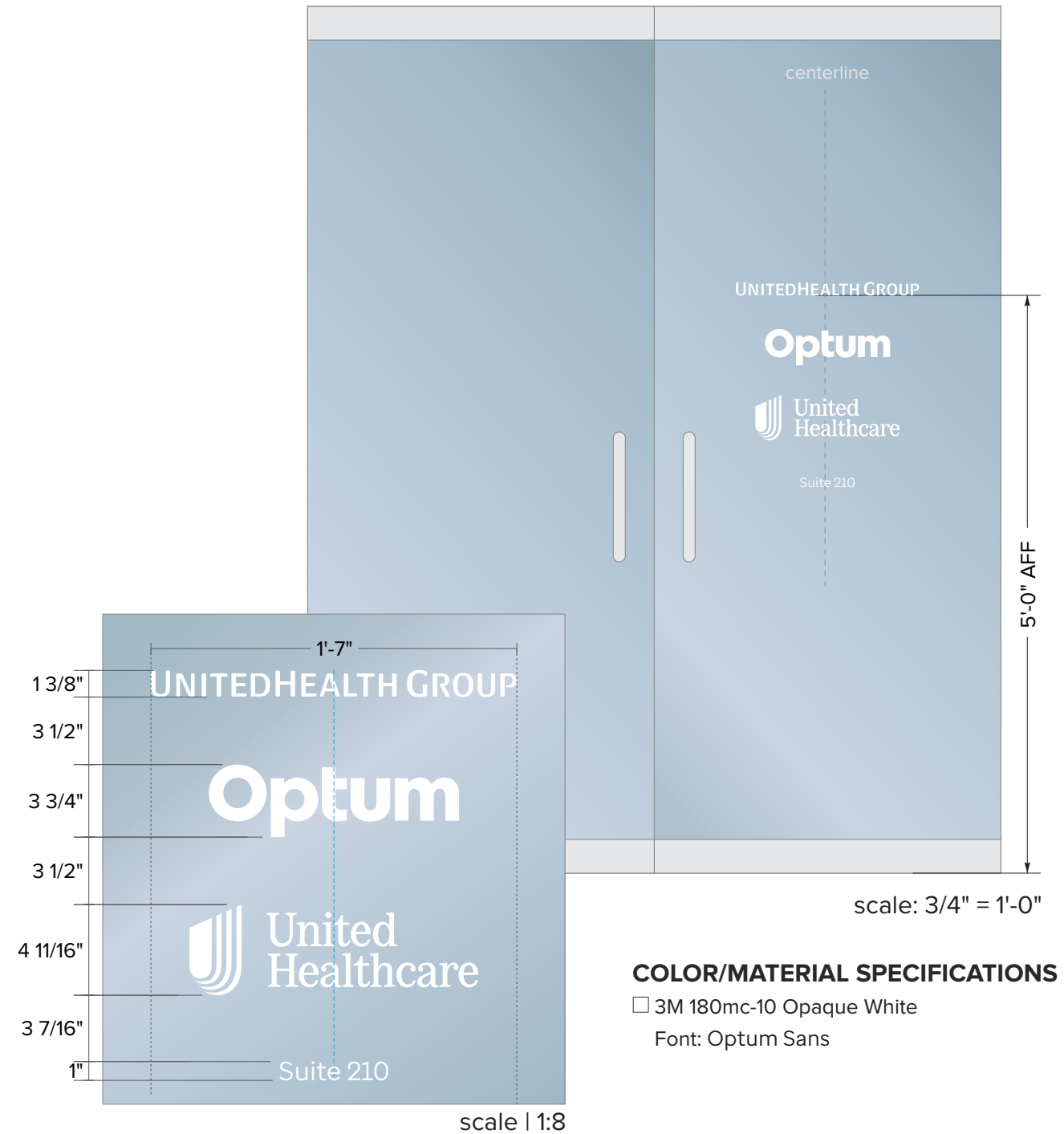

Privacy Vinyl Signage Standards

1. Does the building have a specific criteria to follow for entrance signage?

Yes - Follow Building Standard Sign Criteria.

No - Ask Business if they would like privacy vinyl on suite entrance doors if applicable.

If yes - what type of privacy vinyl would they like?

Full Flood Privacy Vinyl

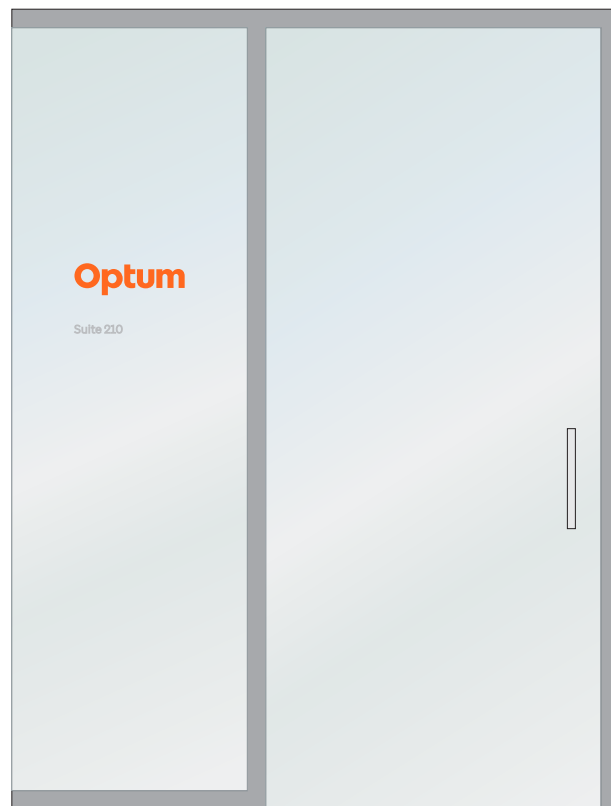

SCALE: 1/2" = 1'-0"

Partial Privacy Vinyl

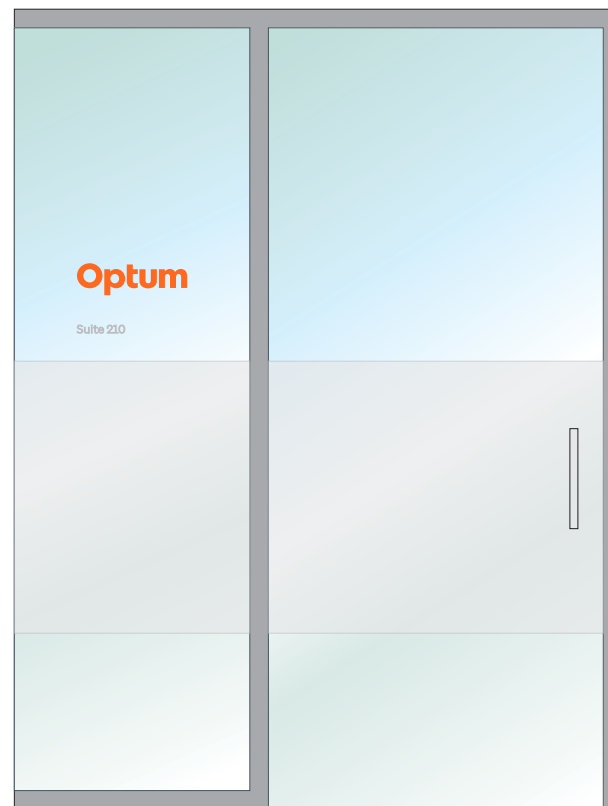

SCALE: 1/2" = 1'-0"

Double Glass Door Privacy Vinyl

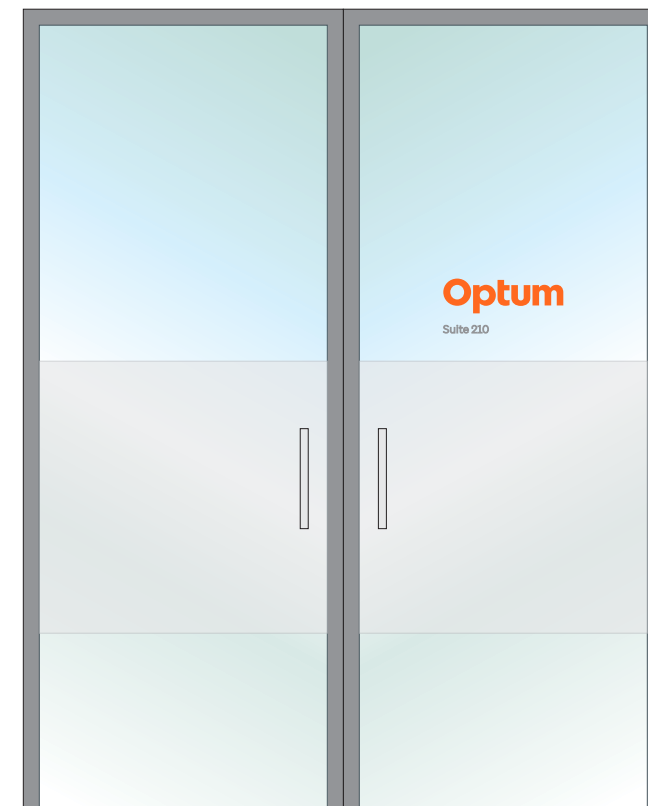

SCALE: 1/2" = 1'-0"

Branded Graphic approved applications:
Huddle Rooms / Conference Rooms / Offices

Suite information to be included with door vinyl only if applicable.

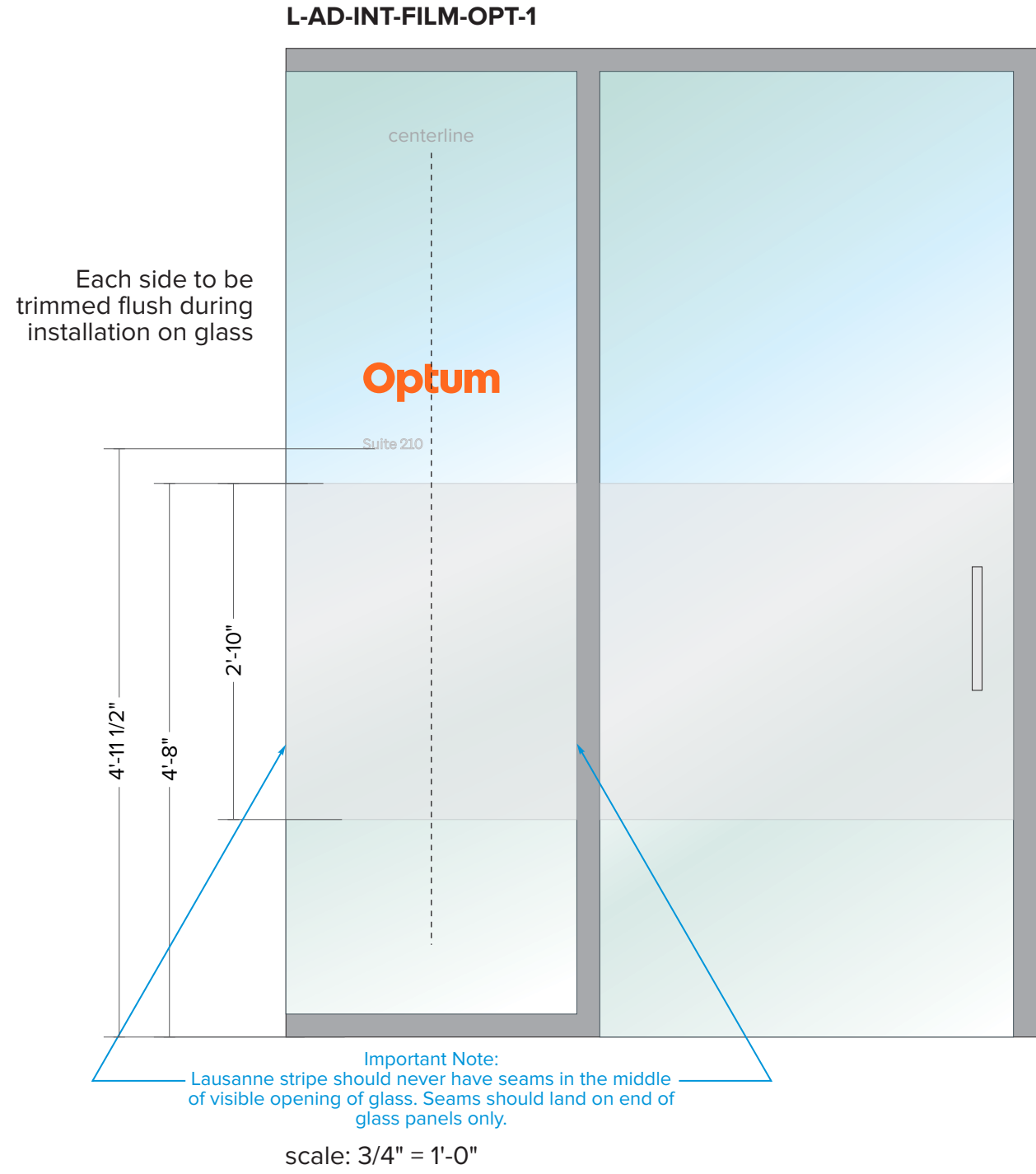

COLOR/MATERIAL SPECIFICATIONS

- 3M #180mc-3289 Opaque Orange
- 3M 180mc-10 Opaque White
- 3M Lausanne Film #SH2EMLA (first surface)
- Font: Optum Sans

LOGO DETAILS:

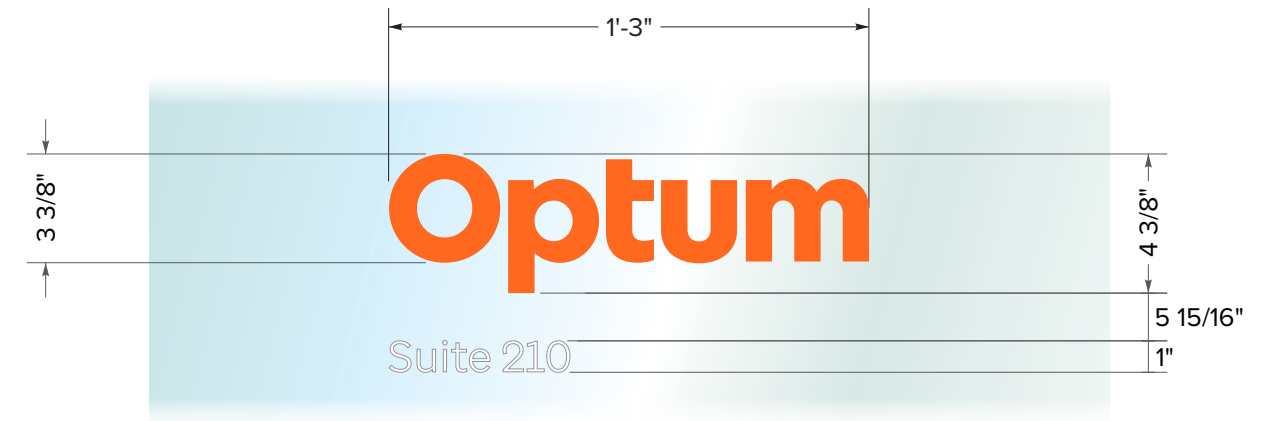

Installation Instructions:

Install entire graphic at 4'-8" from finished floor to top of film.
Graphic is then trimmed to exact visual opening.

Special Note:

No logo is installed on windows.

Full Flood approved applications:
Generally used for Mother's Rooms that have glass doors and windows to ensure full privacy.

Suite information to be included with door vinyl only if applicable.

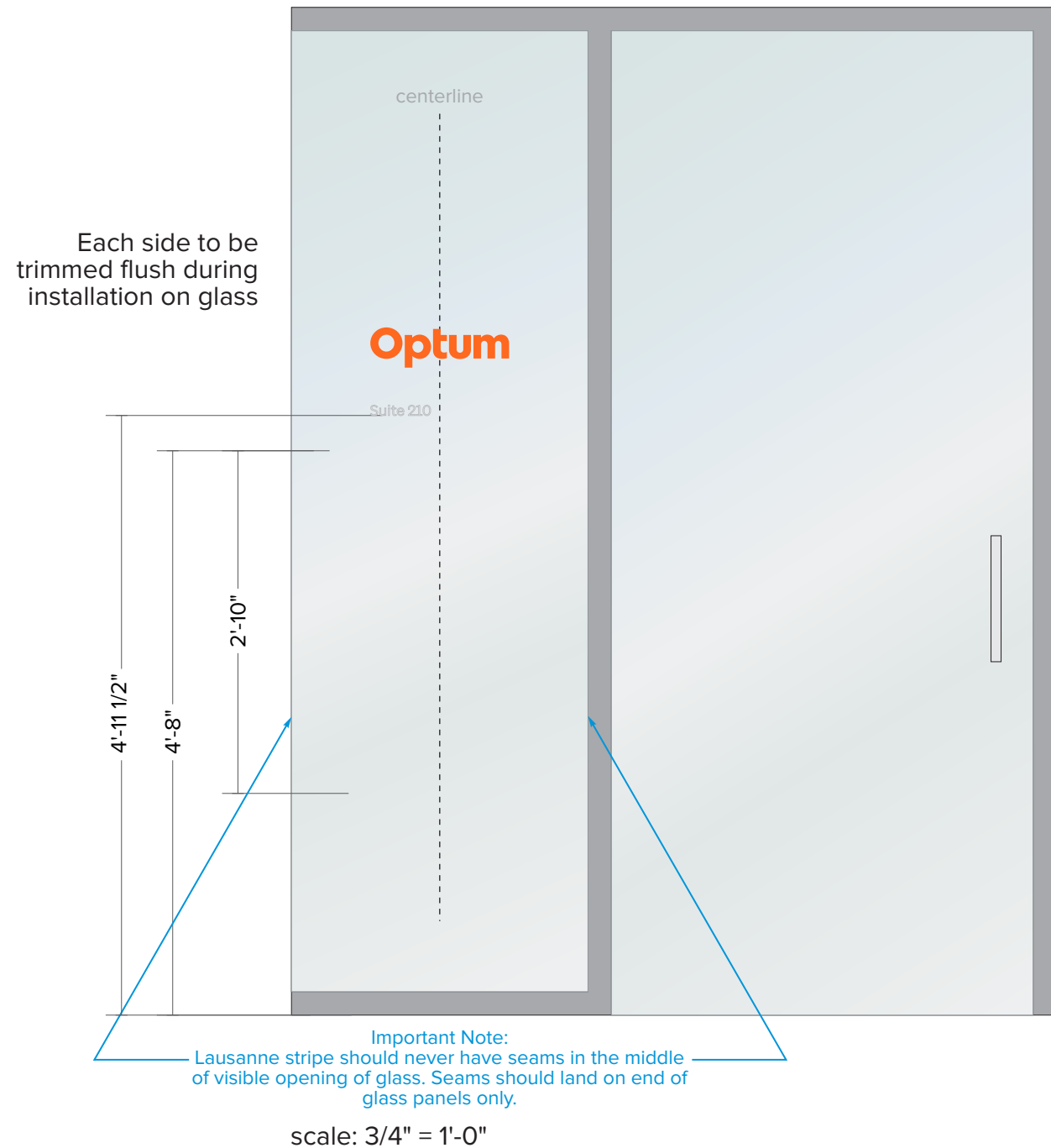

COLOR/MATERIAL SPECIFICATIONS

- 3M #180mc-3289 Opaque Orange
 - 3M 180mc-10 Opaque White
 - Preferred Option: 3M FASARA Glass Finish; SH2EMCRX Milky White (first surface)
Second Option: 3M FASARA #SH2MAGL 1270 - Glace (first surface)
- Note: Vinyl to be cut on 48" rolls and cut to length on site
Font: Optum Sans

LOGO DETAILS:

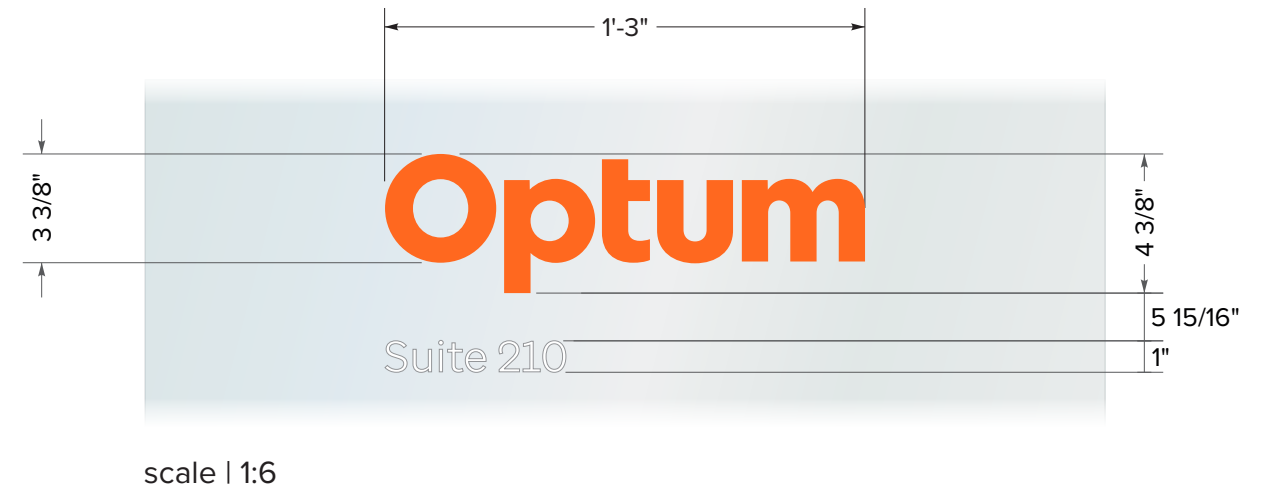

Installation Instructions:

Install film covering glass from finished floor to top of visual opening.
Film is then trimmed to exact visual opening.

3M FASARA Glass Finish



Special Note:

No logo is installed on windows.

Privacy Stripes approved applications:
Utilized for Offices & Conference rooms.



GRAPHICS: 3M FASHARA Glass Finish; SH2EMLA - Lausanne film (first surface)

Note: Vinyl to be cut on 48" rolls and to be cut to length on site

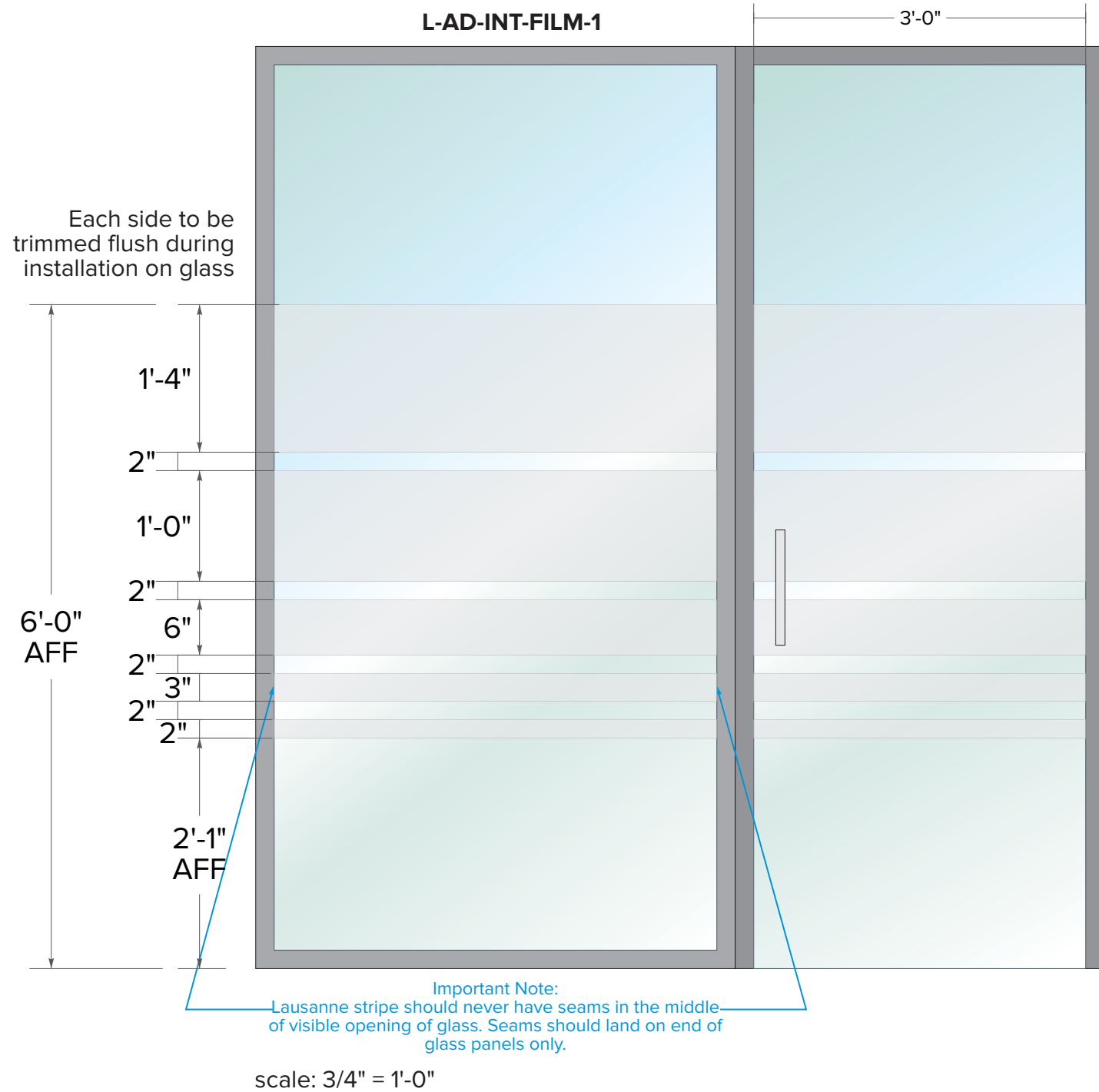

3M FASARA Glass Finish



GRAPHICS: 3M #7725SE-324 Frosted Crystal film

Original artwork to be provided.

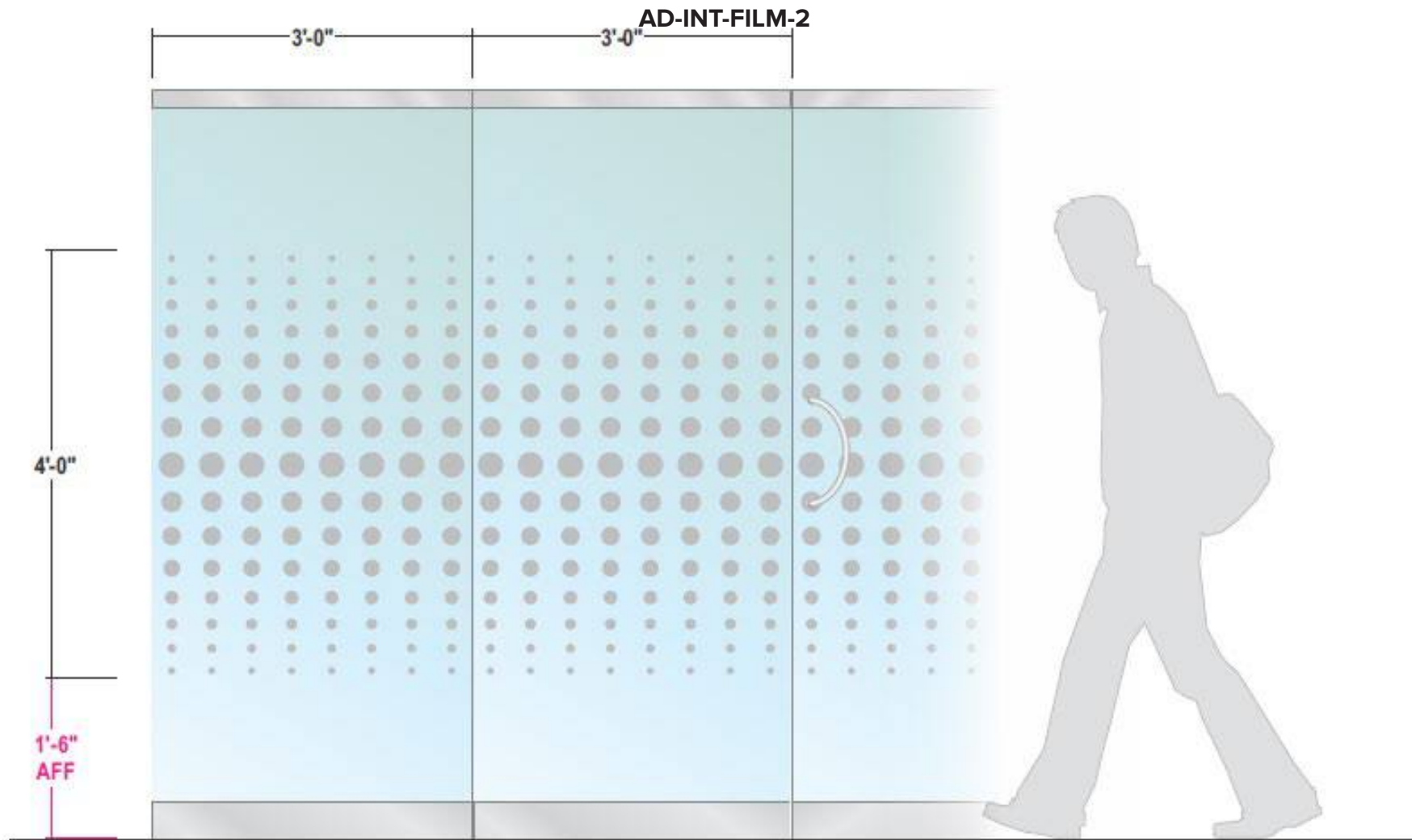

VINYL TO BE OVERSIZED ON EACH END TO ALLOW FOR PROPER FIT

Interior Lettersets

1. Sites with Singular Brand

Utilize line of business workdmark/logo in business preferred brand color.
 All signs must be placed on neutral color background. Never place color logos on bright or highly contrasted walls.

Optum

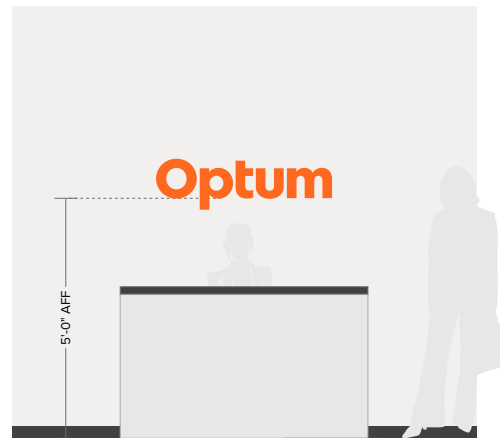

SCALE | 1/4" = 1'

UnitedHeath Group

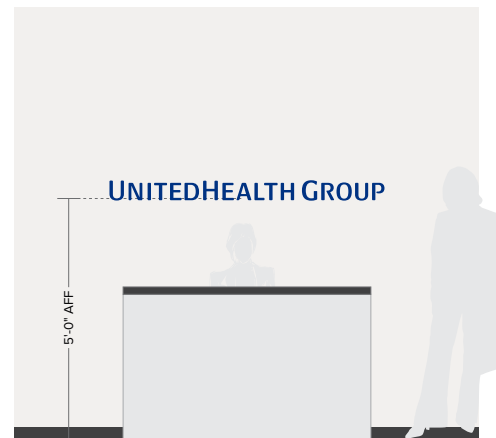

SCALE | 1/4" = 1'

UnitedHealthcare

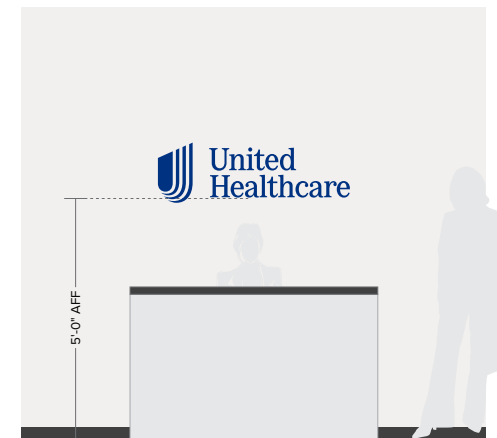

SCALE | 1/4" = 1'

2. Sites with Dual or Tri-Brand

Utilize stainless steel letters.

Dual Brand Layout

Primary Business in location would be first

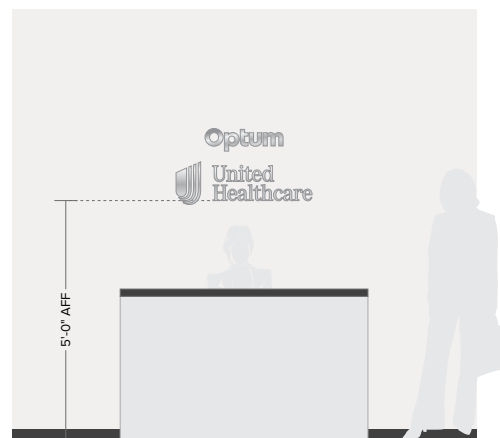

SCALE | 1/4" = 1'

Tri-brand Stacked Layout

UHG / Optum / UHC

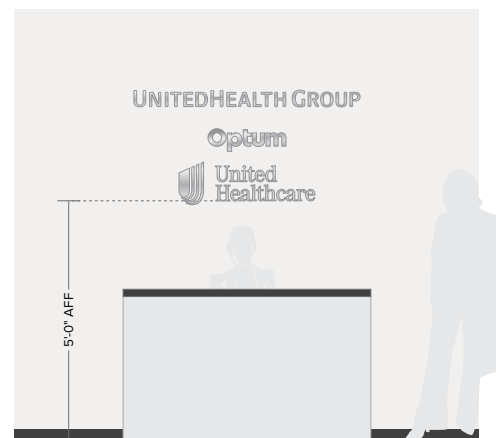

SCALE | 1/4" = 1'

Tri-brand Horizontal Layout

UHG / Optum / UHC

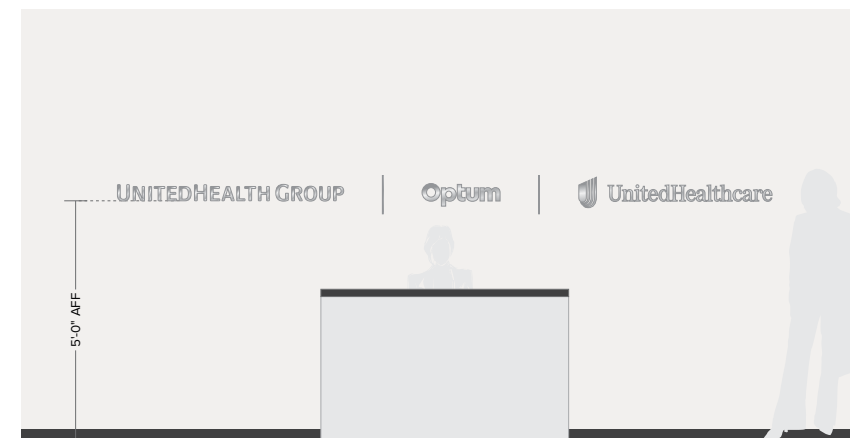

SCALE | 1/4" = 1'

COLOR/MATERIAL SPECIFICATIONS

LETTERSET: 1/4" thick stainless steel, router cut

FINISH: Horizontal Grain finish on faces, sandblasted edges

INSTALL: Stud mount install flush to wall surface. Penetrations to be silicone filled.



Optum

	A	B	C
OC-IL-SS-4	4"	1'-5"	5"
OC-IL-SS-6	6"	2'-2"	7-1/2"
OC-IL-SS-8	8"	2'-11"	10"

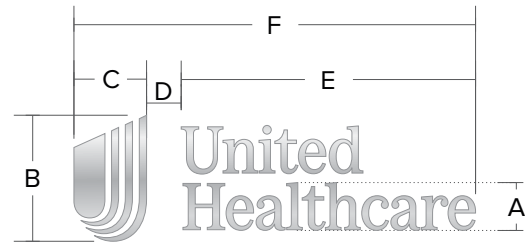

UnitedHealthcare

	A	B	C	D	E	F
UHC-IL-SS-1-4	4"	10 5/8"	6"	3"	2'- 7/8"	2'-10"
UHC-IL-SS-1-6	6"	1'-4"	9 1/4"	4 7/16"	3'-1 9/16"	4'-3 1/4"
UHC-IL-SS-1-8	8"	1-9 5/16"	1'-5/16"	5 7/8"	4'-2"	5'-8 3/16"

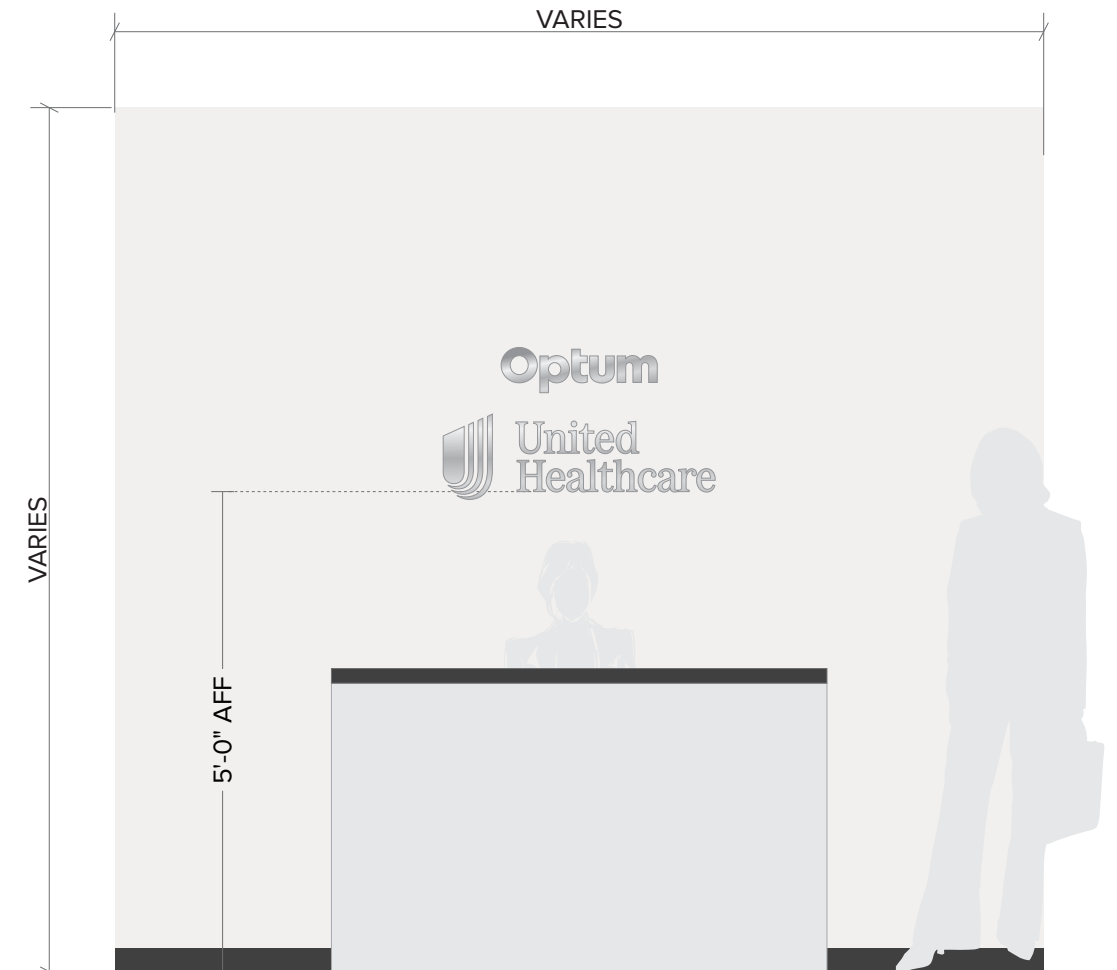

SCALE | 1/2" = 1'

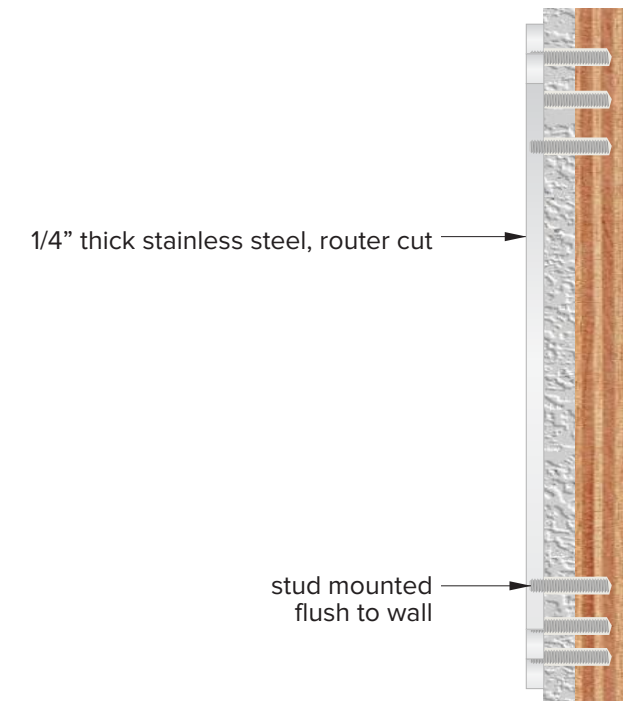

COLOR/MATERIAL SPECIFICATIONS

LETTERSET: 1/4" thick stainless steel, router cut

FINISH: Horizontal Grain finish on faces, sandblasted edges

INSTALL: Stud mount install flush to wall surface. Penetrations to be silicone filled.

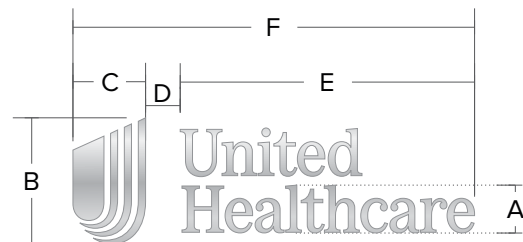

UnitedHealth Group

	A	B
UHG-IL-SS-4	4"	4'-6"
UHG-IL-SS-6	6"	6'-10 1/2"
UHG-IL-SS-8	8"	9'-2"

Optum

	A	B	C
OC-IL-SS-4	4"	1'-5"	5"
OC-IL-SS-6	6"	2'-2"	7-1/2"
OC-IL-SS-8	8"	2'-11"	10"

UnitedHealthcare

	A	B	C	D	E	F
UHC-IL-SS-1-4	4"	10 5/8"	6"	3"	2'- 7/8"	2'-10"
UHC-IL-SS-1-6	6"	1'-4"	9 1/4"	4 7/16"	3'-1 9/16"	4'-3 1/4"
UHC-IL-SS-1-8	8"	1-9 5/16"	1'-5/16"	5 7/8"	4'-2"	5'-8 3/16"

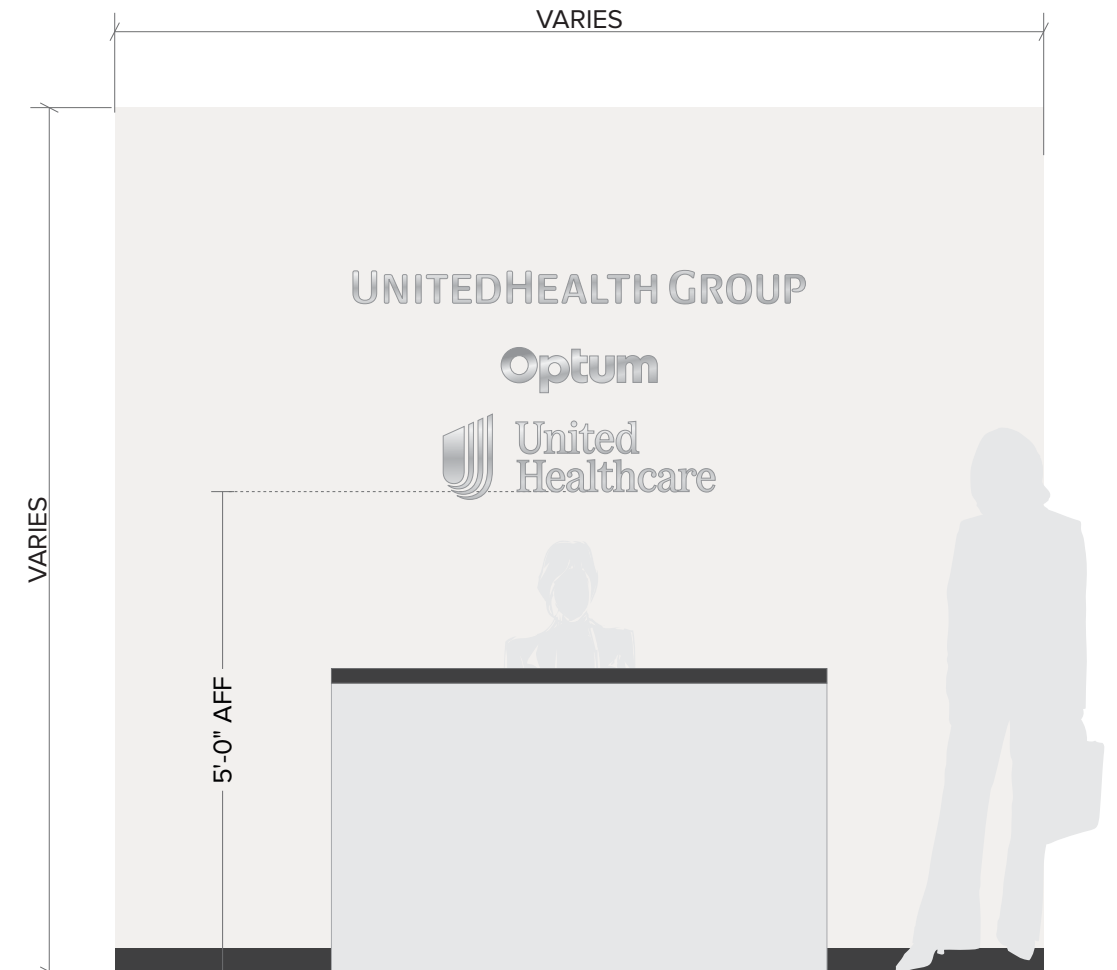

SCALE | 1/2" = 1'

1/4" thick stainless steel, router cut

stud mounted flush to wall



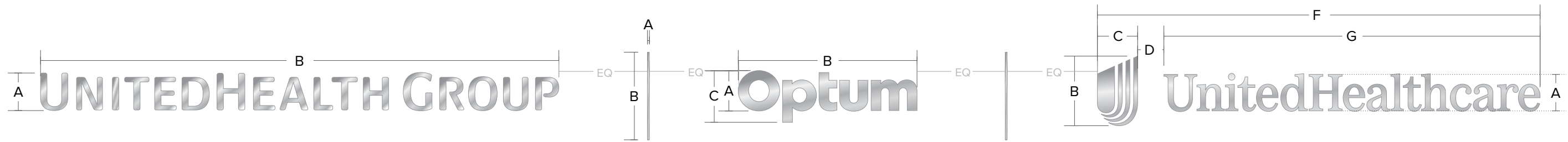

UnitedHealth Group

	A	B
UHG-IL-SS-4	4"	4'-6"
UHG-IL-SS-6	6"	6'-10 1/2"
UHG-IL-SS-8	8"	9'-2"

Divider

	A	B
DIV-IL-SS-4	3/16"	9"
DIV-IL-SS-6	5/16"	1'-2"
DIV-IL-SS-8	7/16"	1'-7"

Optum

	A	B	C
OC-IL-SS-4	4"	1'-5"	5"
OC-IL-SS-6	6"	2'-2"	7-1/2"
OC-IL-SS-8	8"	2'-11"	10"

UnitedHealthcare

	A	B	C	D	E	F
UHC-IL-SS-1-4	4"	7-5/8"	4-1/2"	2-7/8"	3'-5 1/4"	4'-1/2"
UHC-IL-SS-1-6	6"	11-1/2"	6-5/8"	4-3/8"	5'-1 3/4"	6'-5/8"
UHC-IL-SS-1-8	8"	1'-3 1/4"	8-7/8"	5-3/4"	6'-10 3/8"	8'-1"

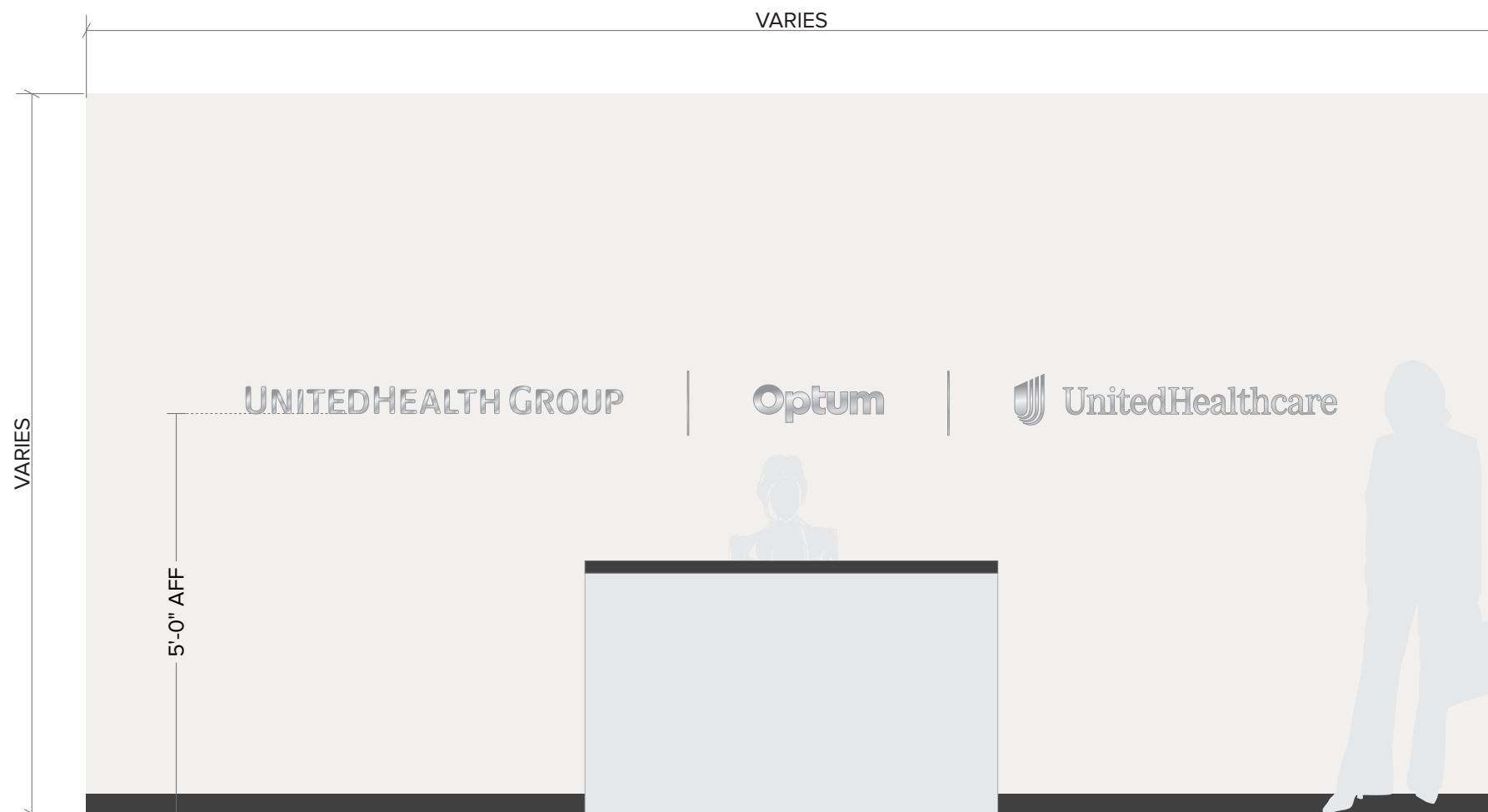

COLOR/MATERIAL SPECIFICATIONS

LETTERSET: 1/4" thick stainless steel, router cut

FINISH: Horizontal Grain finish on faces, sandblasted edges

INSTALL: Stud mount install flush to wall surface. Penetrations to be silicone filled.

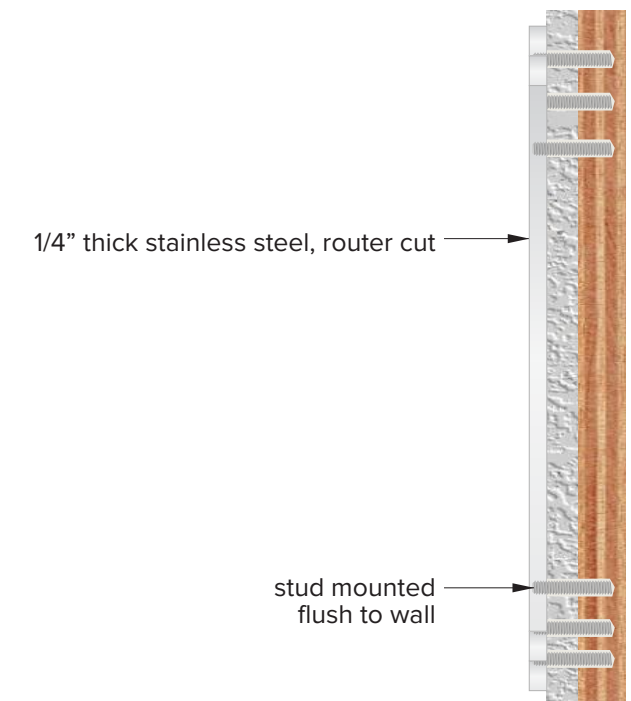

SCALE | 1/2" = 1'

COLOR/ MATERIAL SPECIFICATIONS

■ FCO: 1/4" flat cut out aluminum logo paint to match PMS 2955C

INSTALL: Stud mount flush to interior wall



SCALE: 1" = 1'-0"



SCALE: 1/2" = 1'-0"

Section C

SmartSpot Signage Guidelines



Smart Spot

BRAND SIGNAGE GUIDELINES VERSION 2 // CURRENT: MARCH 2023

Minimum Clear Space Guidelines



Preferred Option White letters with orange brand wall or orange backer panel

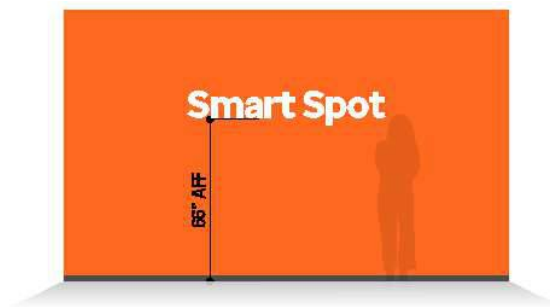

White Letters on Orange Brand Wall

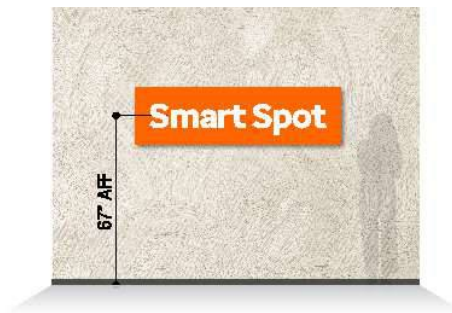

Sign Panel on Wallpapered/Textured Brand Wall

Secondary Option Gray letters with white wall

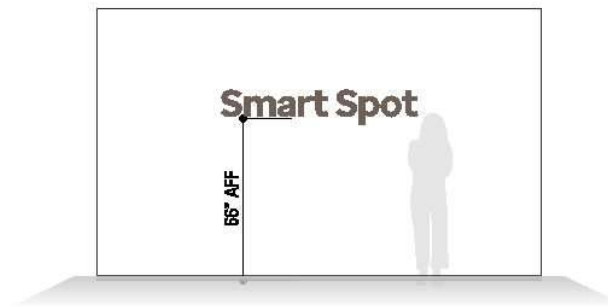

Warm Gray 11C Letters White Brand Wall

Standard Placement Guidelines

****Note: Preferred placement is to have letters next to TV**

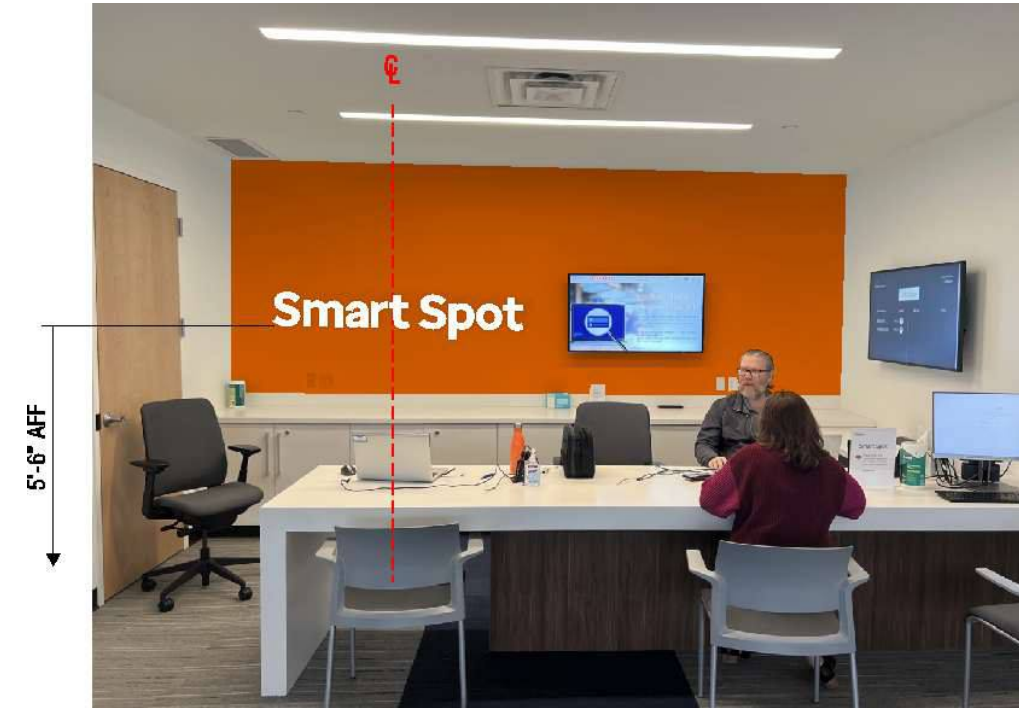

Example - Standard Placement A.F.F.



Example - Placement for Limited Height Areas

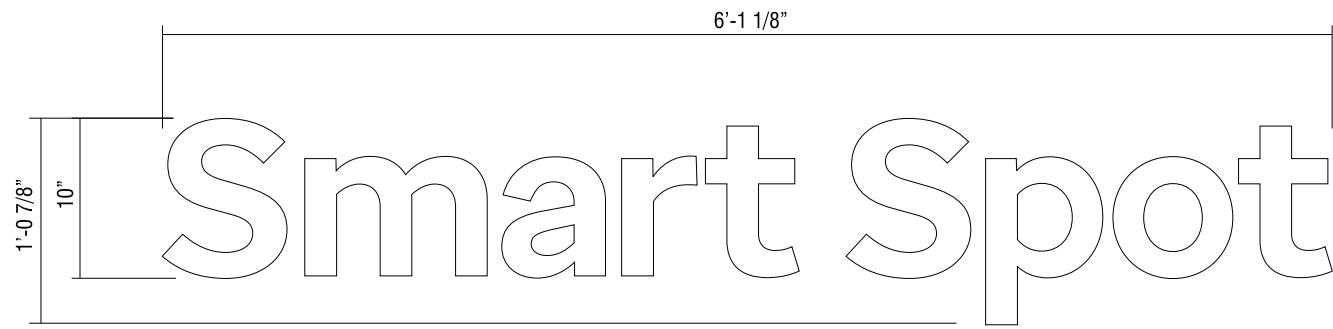

1a | 1 21 INTERIOR FCO LETTER LAYOUT - 10"
SCALE: 1" = 1' 0"

- Remove Existing lettering, repair and paint wall
- Install New Letterset as shown

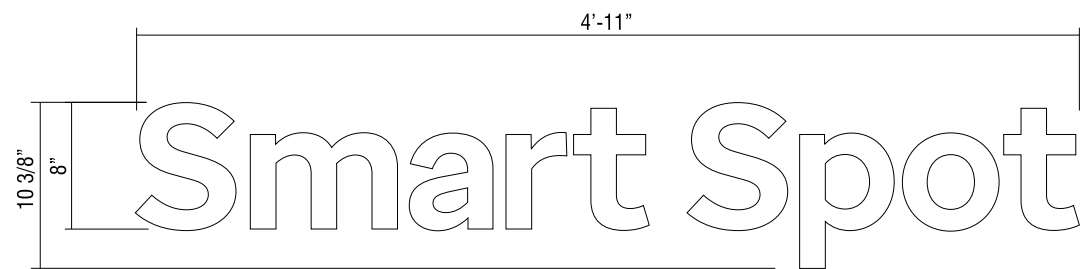

1b | 1 21 INTERIOR FCO LETTER LAYOUT - 8"
SCALE: 1 1/2" = 1' 0"

COLORS & FINISHES:

PAINT:
Wall Painted Optum Orange Matthews Paint MP08528 Engine Orange (PMS Orange 165C)

Letters: White

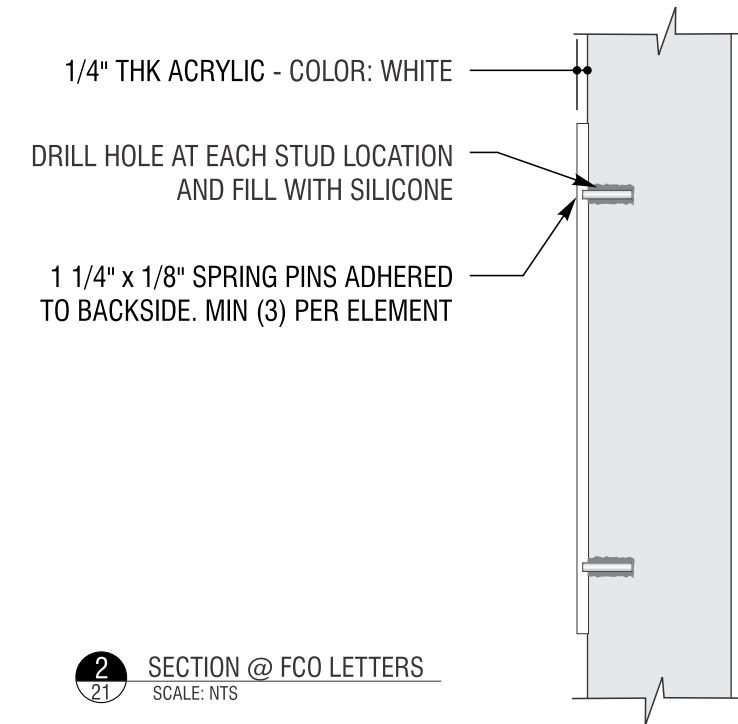

Reference Elevation

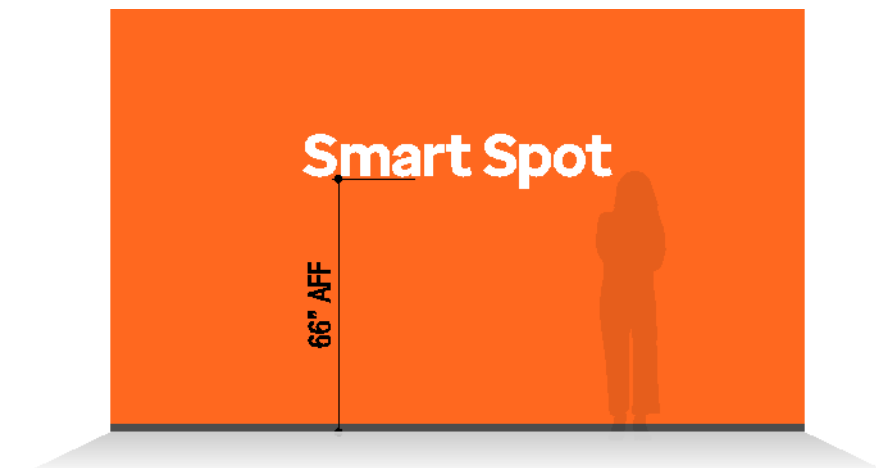



4a 1 INTERIOR FCO LETTER ON BACKGROUND LAYOUT - 10" SCALE: 1" = 1' - 0"

- Remove Existing lettering, repair and paint wall
- Install New Letterset as shown

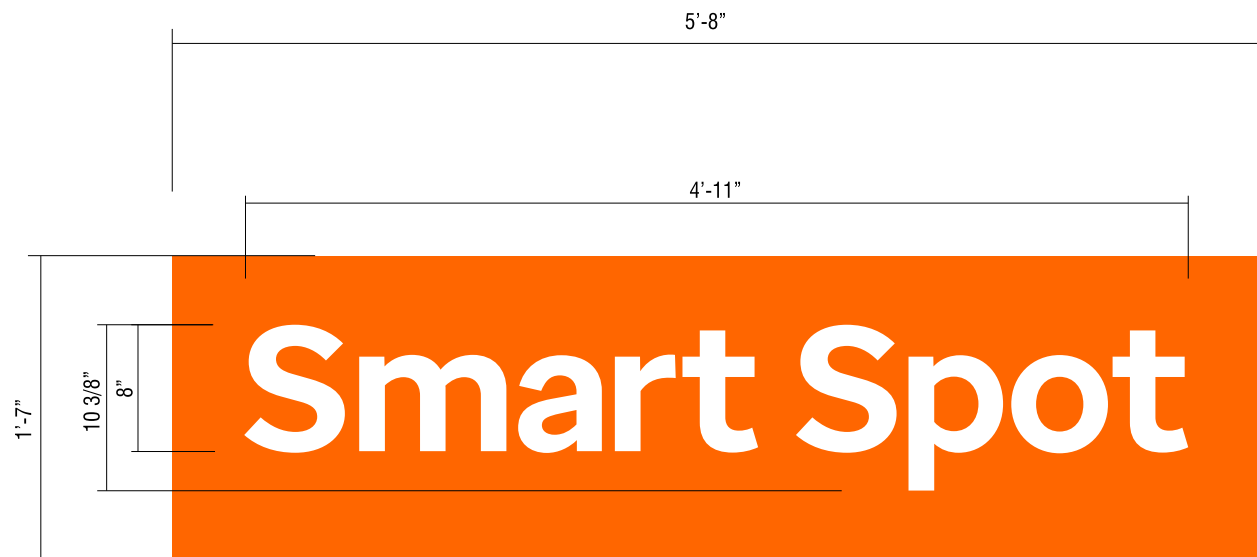

4b 1 INTERIOR FCO LETTER ON BACKGROUND LAYOUT - 8" SCALE: 1" = 1' - 0"

COLORS & FINISHES:

PAINT:
Background Painted Optum Orange Matthews Paint MP08528 Engine Orange (PMS Orange 165C)

Letters: White

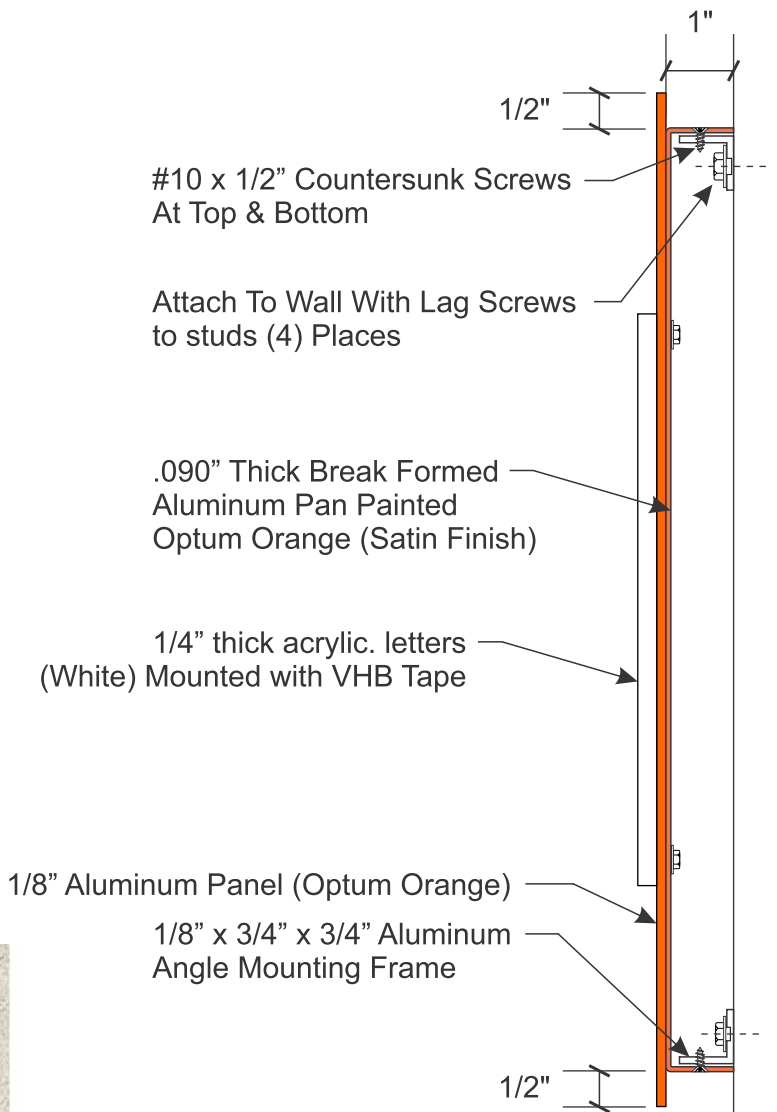

2 SECTION @ Reception Panel Sign SCALE: NTS

Reference Elevation

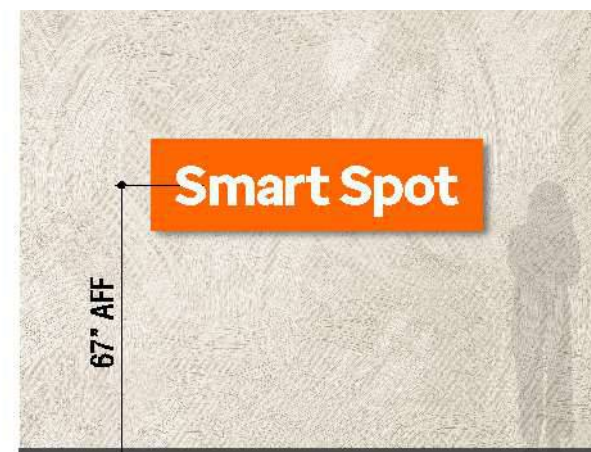



3a | 1
21 INTERIOR FCO LETTER LAYOUT - 10"
SCALE: 1" = 1' 0"

- Remove Existing lettering, repair and paint wall
- Install New Letterset as shown

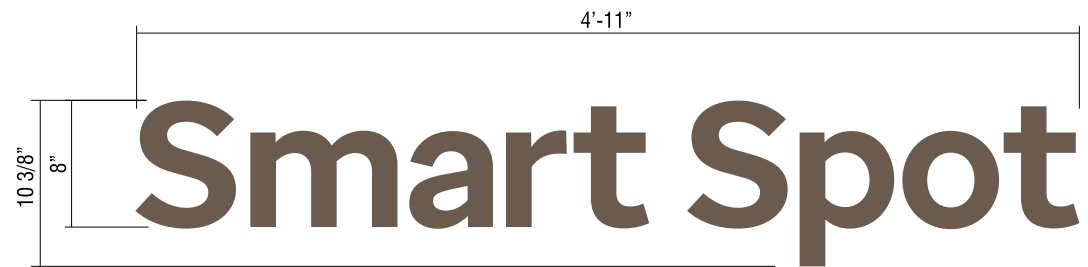

3b | 1
21 INTERIOR FCO LETTER LAYOUT - 8"
SCALE: 1 1/2" = 1' 0"

COLORS & FINISHES:

PAINT:
Letters: Painted PMS Warm Gray 11C

1/4" THK ACRYLIC - COLOR: WARM GRAY 11C

DRILL HOLE AT EACH STUD LOCATION
AND FILL WITH SILICONE

1 1/4" x 1/8" SPRING PINS ADHERED
TO BACKSIDE. MIN (3) PER ELEMENT

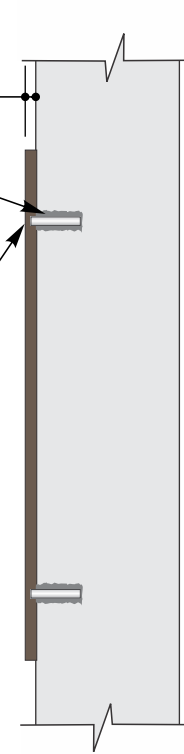

2
21 SECTION @ FCO LETTERS
SCALE: NTS

Reference Elevation

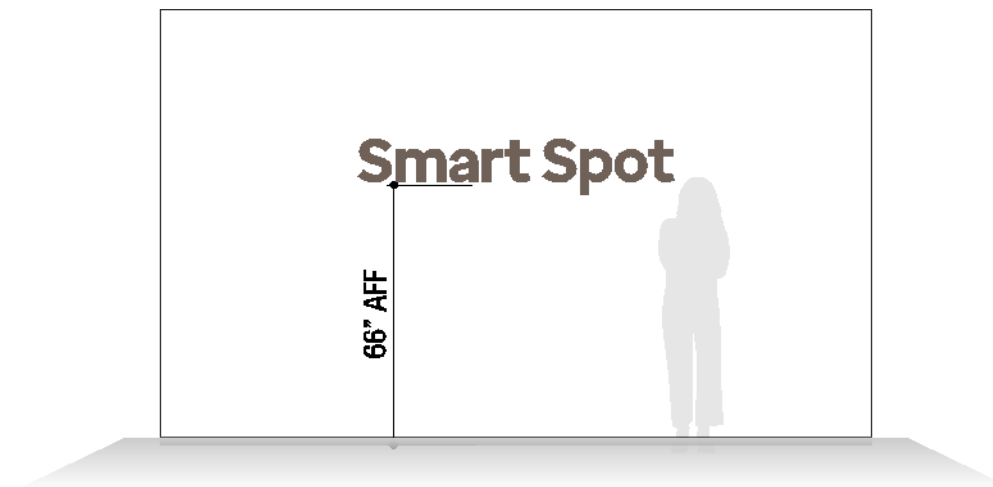

ADA Suite Room Signage Standards

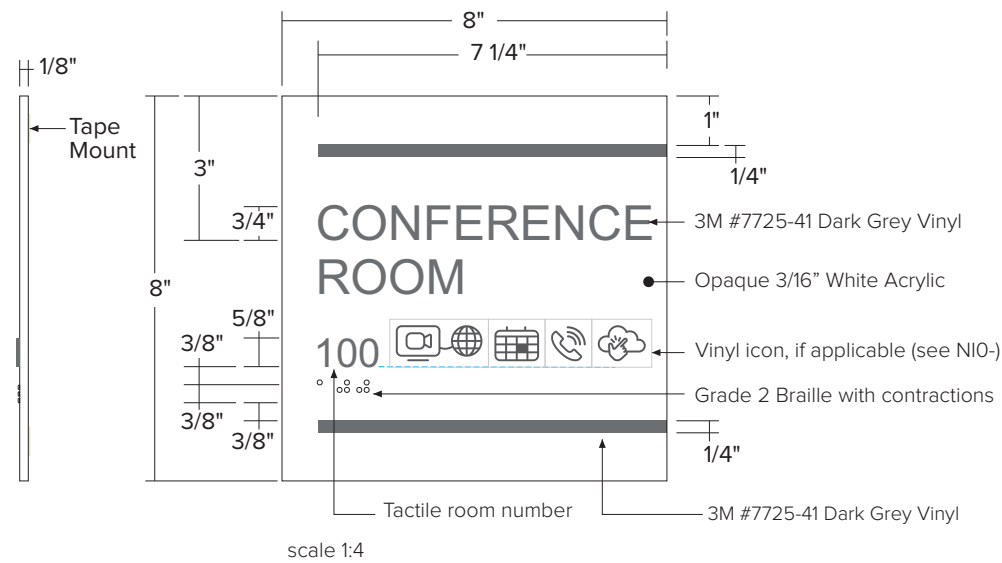

COLOR/ MATERIAL SPECIFICATIONS

- PANEL: 1/8" thick acrylic surface painted Akzo Nobel 493-A1 White, Matte finish
- COPY: Room name/number to be 1/32" raised tactile copy in Rowmark Charcoal;
 - Accent Lines to be surface applied 3M #7725-41 Dark Grey vinyl;
 - Icons to be optically clear vinyl decals with digitally printed Dark Grey symbol

** Room Icon's are determined by the equipment included in the sites conference room. Signage Partner to work with Site PM to determine equipment and icons needed.*

FONT: Arial Regular

BRAILLE: Grade II - Clear Braille Rasters

INSTALL: Install flush to wall with silicone and 3M 1/8" White Double-Faced Foam tape

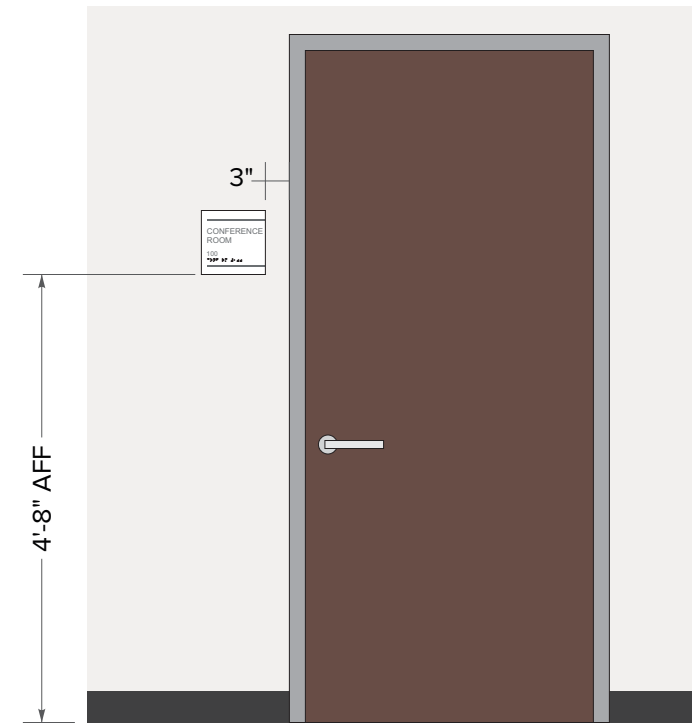

WALL MOUNT
SCALE: 1/2" = 1'-0"

<p>1" x 2.1044" Overall Size</p> <p>BYOD Video</p> <p>Use: Huddle Team Huddle Small Conference Room</p>	<p>1" x 1.796" Overall Size</p> <p>LCD</p> <p>Use: POD Multipurpose Room</p>	<p>1" x 2.0549" Overall Size</p> <p>Networked Video</p> <p>Use: Medium Conference Room Large Conference Room XL Conference Room Presentation Room Sandbox</p>	<p>1" x 1.796" Overall Size</p> <p>Reservable</p> <p>Use: Small Conference Room Medium Conference Room Large Conference Room XL Conference Room Presentation Room Sandbox Multipurpose Room</p>	<p>1" x .9725" Overall Size</p> <p>Speaker Phone</p> <p>Use: Huddle Small Conference Room Medium Conference Room Large Conference Room XL Conference Room Presentation Room Sandbox Multipurpose Room</p>	<p>1" x 1.25" Overall Size</p> <p>Click to Join</p> <p>Use: Small Conference Room Medium Conference Room Large Conference Room</p>
---	--	---	---	---	--



VINYL BACKER
For glass mount applications, include a vinyl backer applied first surface to interior of glass to conceal tape mounting.

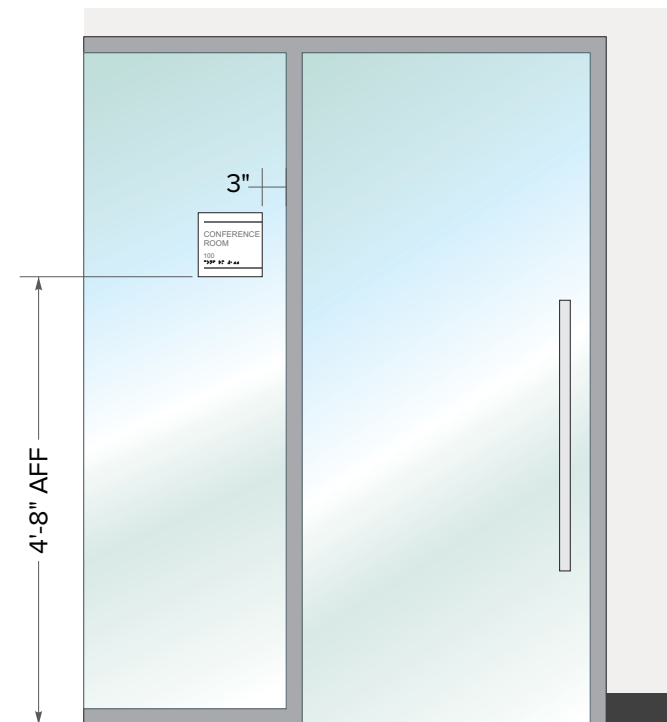

GLASS MOUNT - SIDE LIGHT
SCALE: 1/2" = 1'-0"

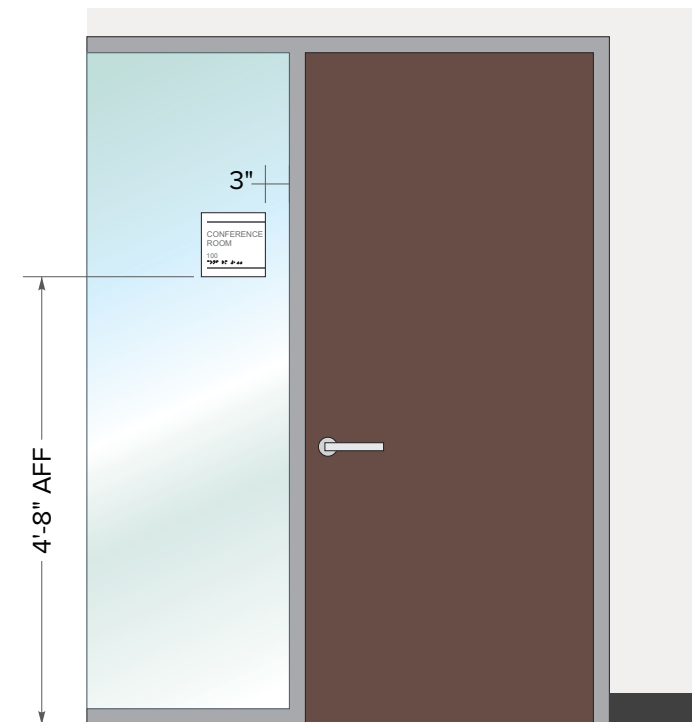

GLASS MOUNT - SIDELIGHT
SCALE: 1/2" = 1'-0"

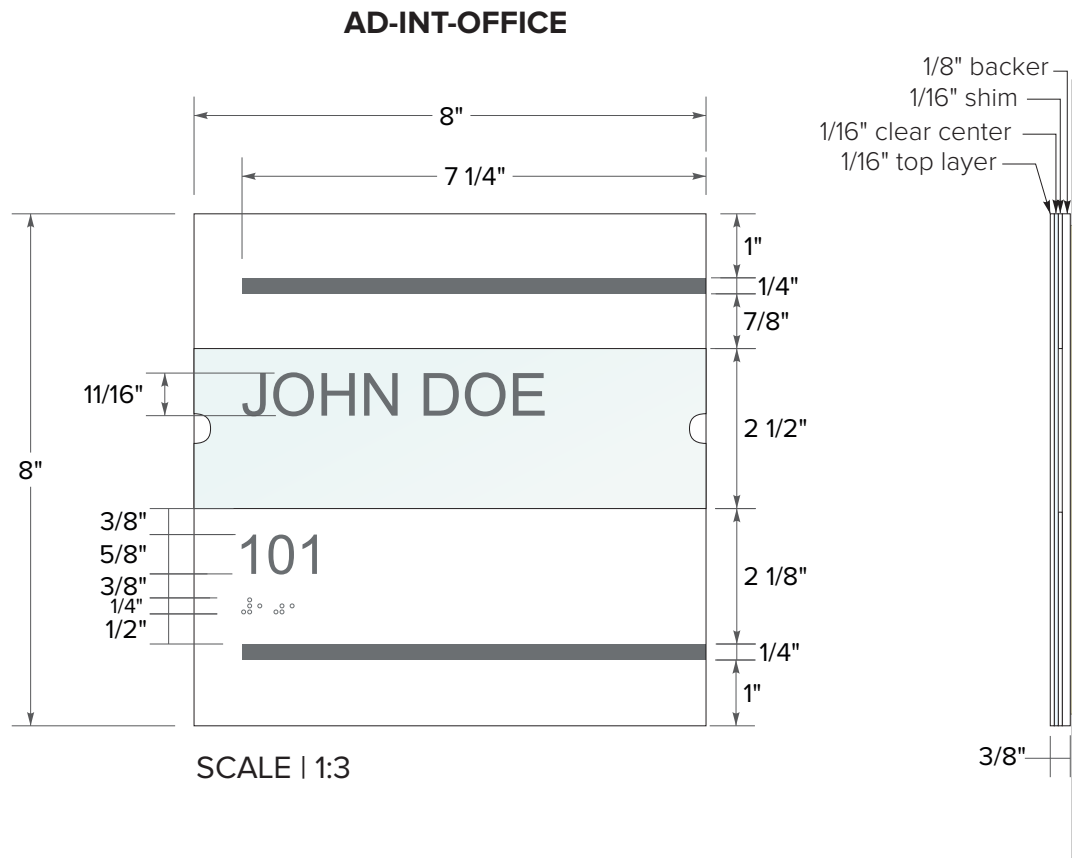

COLOR/ MATERIAL SPECIFICATIONS

- BACKER: 1/8" thick acrylic surface painted Akzo Nobel 493-A1 White, Matte finish
- CENTER SHIM: 1/16" thick acrylic cut to same size as top layer panels
- CENTER PLATE: 1/16" thick non-glare, matte finish clear acrylic with routed thumb slot
- TOP LAYER: 1/16" thick white acrylic painted Akzo Nobel 493-A1 White, Matte finish with surface applied vinyl rule lines in
 - 3M #7725-41 Dark Grey vinyl
- COPY: Room number to be 1/32" raised Rowmark Charcoal Grey
Room name to be cardstock paper insert with laser printed copy

FONT: Arial Regular

BRaille: Grade II - Clear Braille Rasters

INSTALL: Install flush to wall with silicone and 3M 1/8" White Double-Faced Foam tape

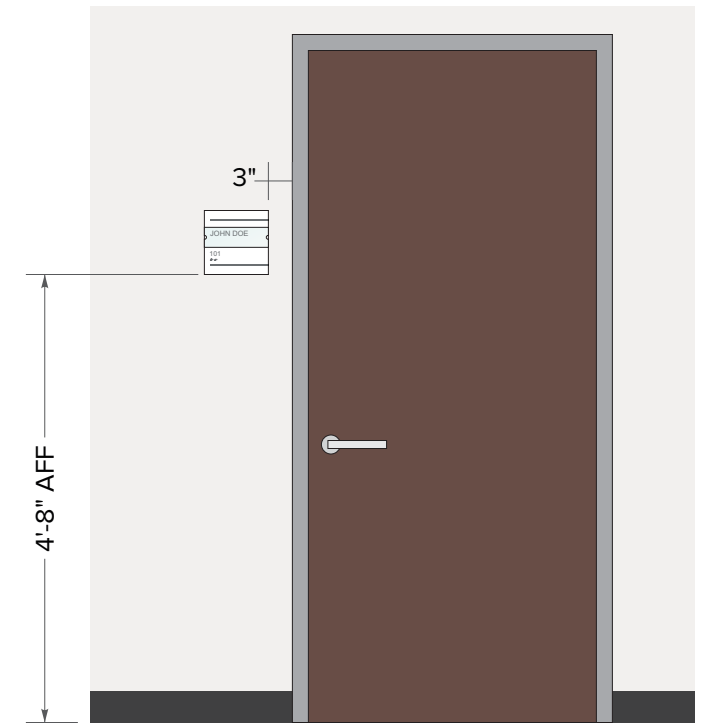

WALL MOUNT
SCALE: 1/2" = 1'-0"

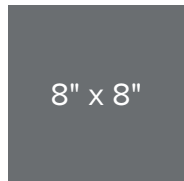

VINYL BACKER

For glass mount applications, include a vinyl backer applied first surface to interior of glass to conceal tape mounting.

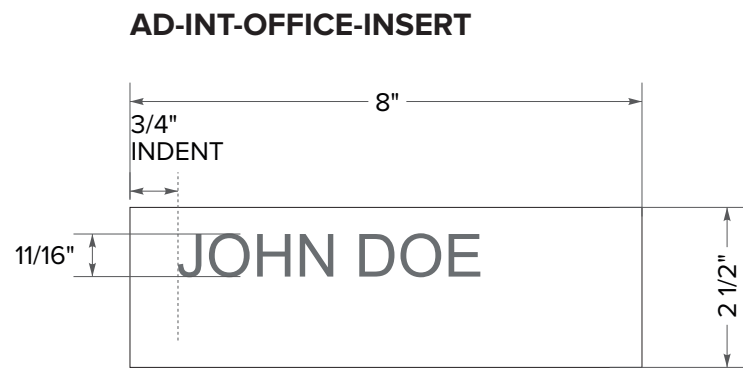

* Insert to be left blank if no office name is assigned.

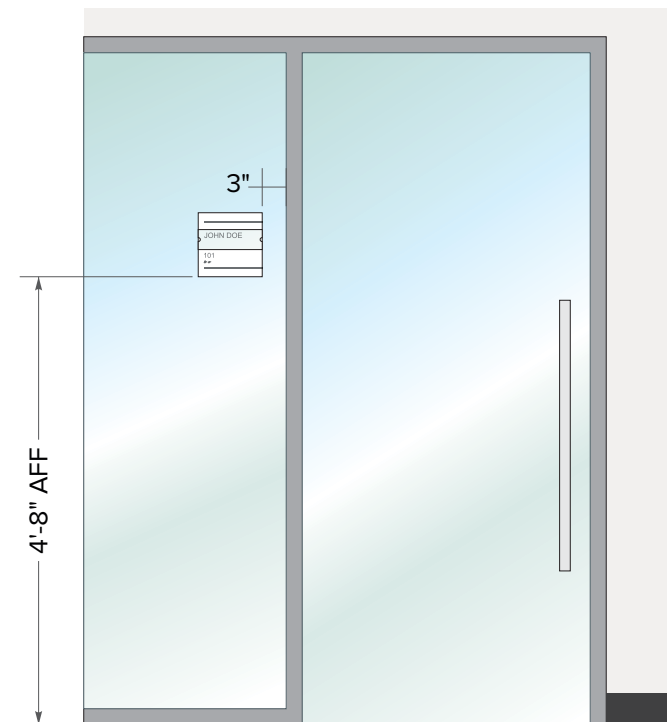

GLASS MOUNT - SIDE LIGHT
SCALE: 1/2" = 1'-0"

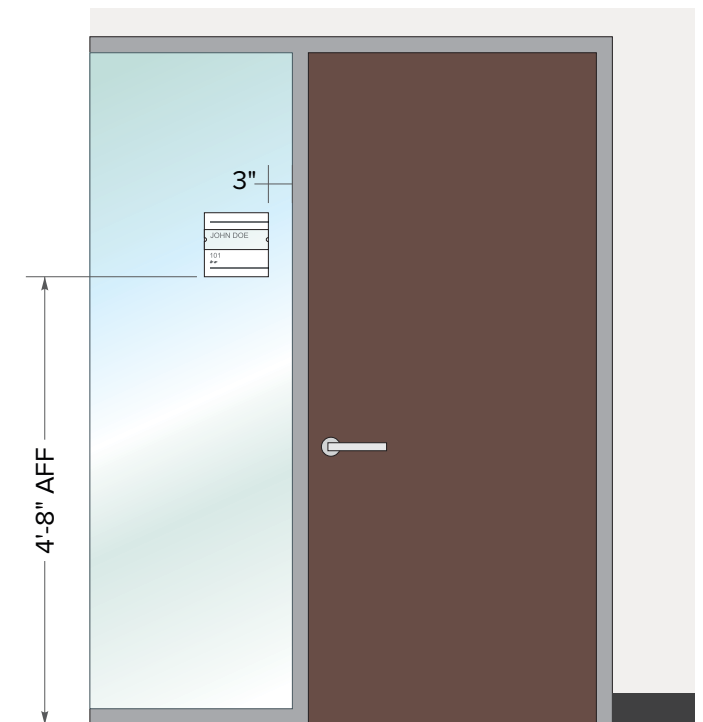

GLASS MOUNT - SIDELIGHT
SCALE: 1/2" = 1'-0"

Typical Glass Sidelight Elevation

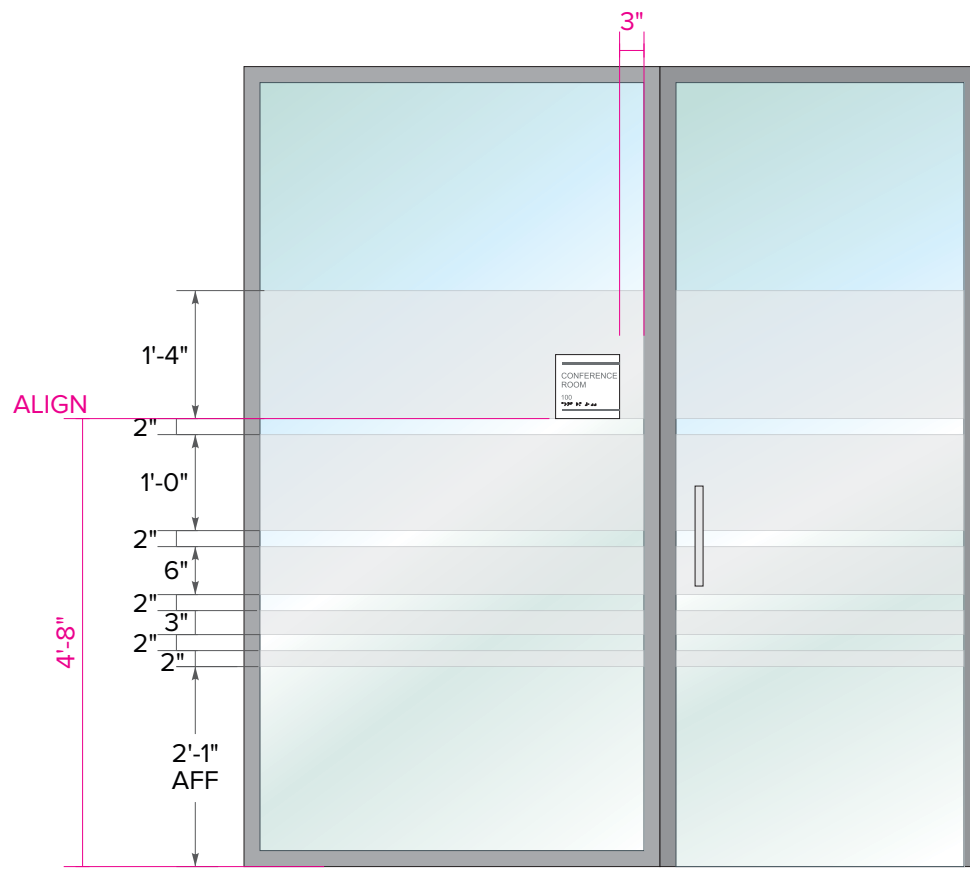

scale: 1/2" = 1'-0"

Signs to be installed on glass side light, 3" from the door on the latch side. Bottom of the sign to align w/ bottom of top line of film as shown.

Film must be installed prior to sign, but before hardware is installed on doors.

Typical Glass Sidelight Elevation

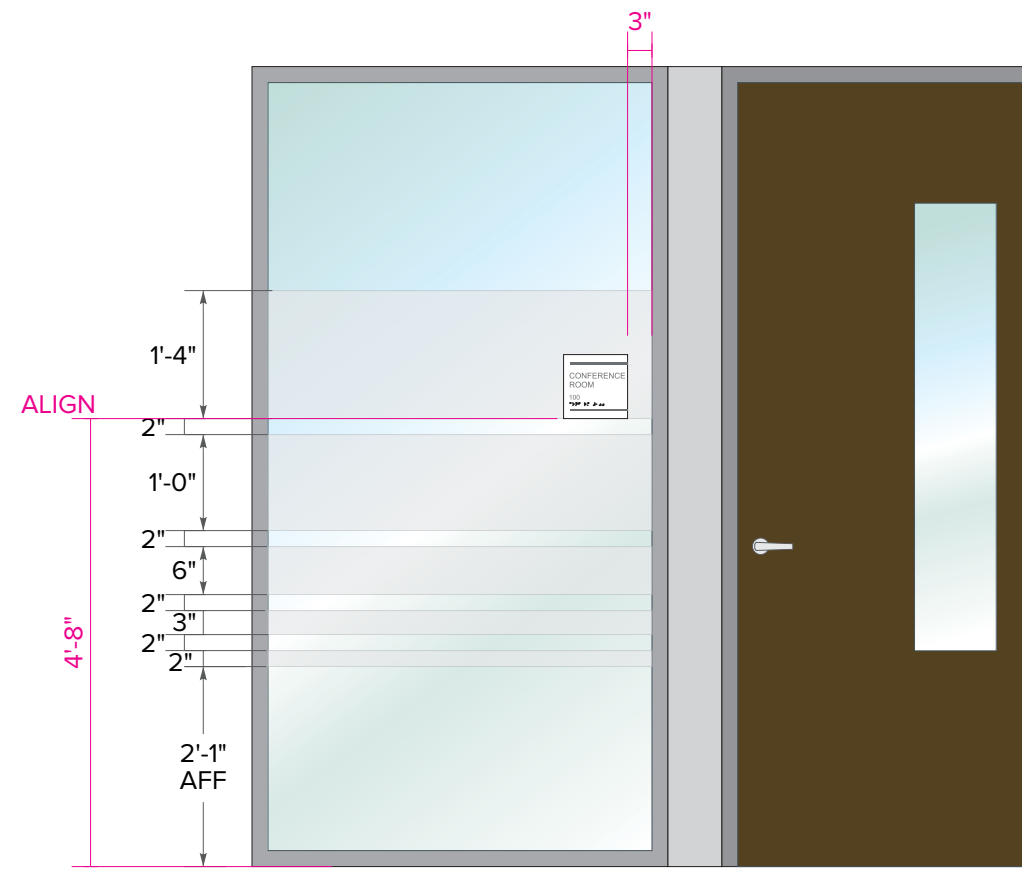

scale: 1/2" = 1'-0"

Signs to be installed on glass side light, 3" from mullion on latch side of door if there is not room to install on wall. Bottom of sign to align w/ bottom of top line of film as shown.

Typical Sliding Glass Door Elevation

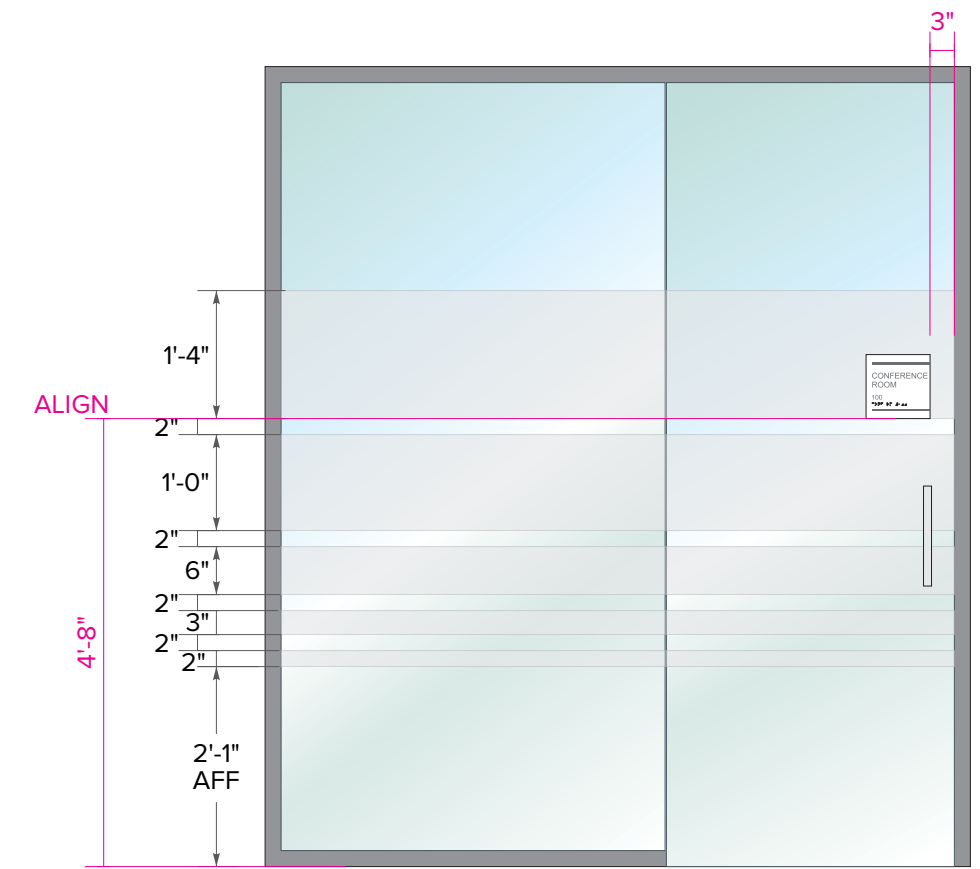

scale: 1/2" = 1'-0"

Signs to be installed on glass side light, 3" from the door on the latch side. Bottom of the sign to align w/ bottom of top line of film as shown.

Film must be installed prior to sign, but before hardware is installed on doors.

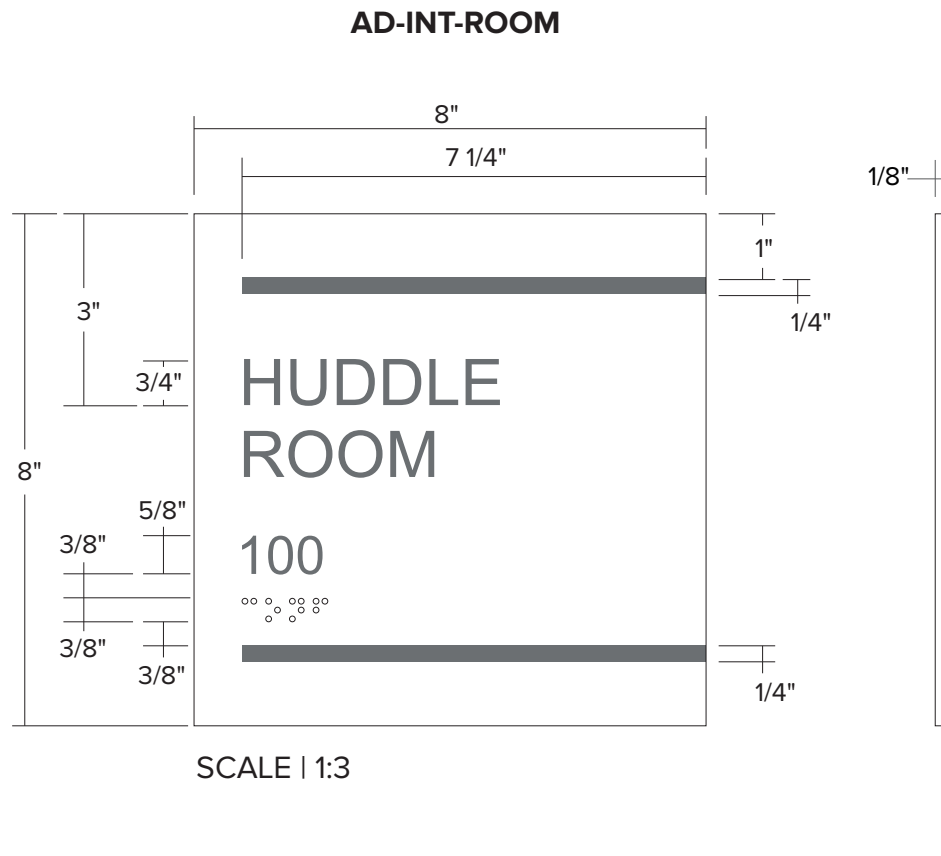

COLOR/ MATERIAL SPECIFICATIONS

- PANEL: 1/8" thick acrylic surface painted Akzo Nobel 493-A1 White, Matte finish
 - COPY: Room name/number to be 1/32" raised tactile copy in Rowmark Charcoal;
 - Accent Lines to be surface applied 3M #7725-41 Dark Grey vinyl;
- *Reference page 8 for all Room ID naming conventions.*

FONT: Arial Regular

BRAILLE: Grade II - Clear Braille Rasters

INSTALL: Install flush to wall with silicone and 3M 1/8" White Double-Faced Foam tape



VINYL BACKER

For glass mount applications, include a vinyl backer applied first surface to interior of glass to conceal tape mounting.

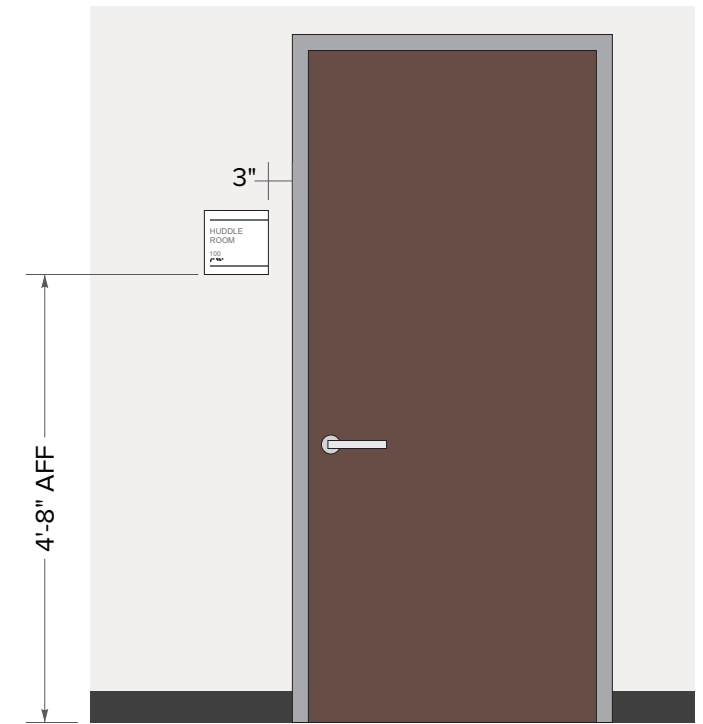

WALL MOUNT
SCALE: 1/2" = 1'-0"

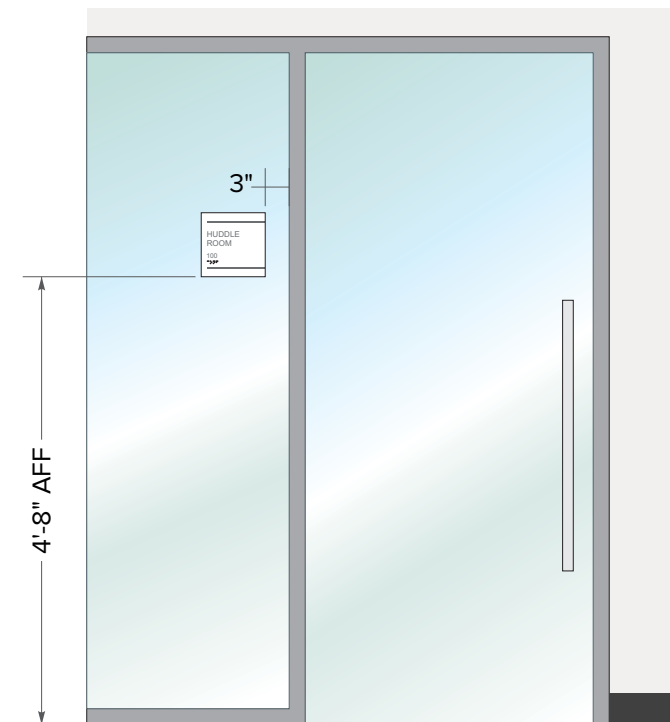

GLASS MOUNT - SIDE LIGHT
SCALE: 1/2" = 1'-0"

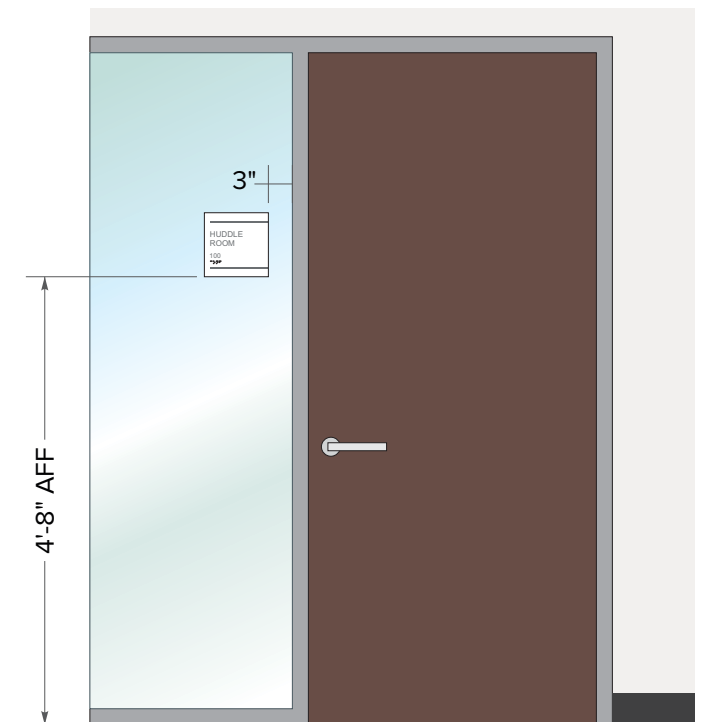

GLASS MOUNT - SIDELIGHT
SCALE: 1/2" = 1'-0"

ROOM NAME SHOWN ON PLAN	UHG PREFERRED VERBIAGE
A/V	A/V CLOSET
A/V Rack Room	A/V CLOSET
AUDIOLOGIST	AUDIOLOGIST
AUDITORIUM	AUDITORIUM
BIKE STORAGE	BIKE STORAGE
BLDG AUTOMATION SYSTEM	BLDG CONTROL ROOM
BOARDROOM	BOARDROOM
CLOSET	CLOSET
COATS	COAT ROOM
COFFEE BAR	COFFEE BAR
CONFERENCE - EXTRA LARGE	CONFERENCE ROOM
CONFERENCE - LARGE	CONFERENCE ROOM
CONFERENCE - MEDIUM	CONFERENCE ROOM
CONFERENCE - SMALL	CONFERENCE ROOM
CONFERENCE - VIDEO	CONFERENCE ROOM
CONTROL ROOM	CONTROL ROOM
CREDIT UNION	CREDIT UNION
C-STORE	CONVENIENCE STORE
DINING ROOM	DINING ROOM
DRESSING ROOM	DRESSING ROOM
ELECTRICAL	ELECTRICAL ROOM
ELECTRICAL ROOM - MAIN	MAIN ELECTRICAL ROOM
ELEVATOR	NO SIGN NEEDED
ELEVATOR - SERVICE or FREIGHT	SERVICE ELEVATOR
ELEVATOR EQUIPMENT ROOM	ELEVATOR EQUIPMENT ROOM
ELEVATOR LOBBY	NO SIGN NEEDED
ELEVATOR MACHINE ROOM	ELEVATOR MACHINE ROOM
ELEVATOR PENTHOUSE	ELEVATOR PENTHOUSE
ELEVATOR PIT	ELEVATOR PIT
ENCLAVE	ENCLAVE
FIRE COMMAND ROOM	FIRE COMMAND ROOM
FIRE PUMP / RISER	FIRE PUMP / RISER
FIRE SUPPRESSION	FIRE SUPPRESSION
FITNESS	FITNESS CENTER
FOCUS	FOCUS ROOM
FULFILLMENT	FULFILLMENT ROOM
GAME ROOM	GAME ROOM
HEALTH CARE ADVISOR	
HUDDLE	HUDDLE ROOM
IDF	IDF ROOM
INTERVIEW	INTERVIEW ROOM
IT WORKROOM	IT WORKROOM
JANITOR	JANITORIAL ROOM
LIBRARY	LIBRARY
LOADING DOCK	LOADING DOCK
MAIL/COPY	MAIL ROOM
MDF	MDF ROOM
MECHANICAL	BUILDING MECHANICAL
MEN'S (UNLESS AHJ REQUIRES OTHERWISE)	MEN

ROOM NAME SHOWN ON PLAN	UHG PREFERRED VERBIAGE
MEN'S LOCKER ROOM	MEN'S LOCKER ROOM
MOTHER'S ROOM	MOTHER'S ROOM
MOTHER'S SUITE	MOTHER'S SUITE
MULTI-PURPOSE	MULTI-PURPOSE ROOM
NOT IN CONTRACT	NO SIGN NEEDED
NOT IN SCOPE	NO SIGN NEEDED
OFFICE	AD-INT-OFFICE with Insert
OPEN OFFICE	NO SIGN NEEDED
POD	POD
PRE-FUNCTION LOBBY	NO SIGN NEEDED
PRESENTATION	PRESENTATION ROOM
PRESENTATION - XL	PRESENTATION ROOM
PROJECT ROOM	PROJECT ROOM
PURE EXPRESS	NO SIGN NEEDED
PURE MARKET	NO SIGN NEEDED
RECEPTION	NO SIGN NEEDED
RESTROOM	RESTROOM
RETREAT	RETREAT
SANDBOX	SANDBOX
SERVICE CENTER	SERVICE CENTER
SMARTSPOT	NO SIGN NEEDED
STAIR	STAIR
STORAGE	STORAGE ROOM
STORAGE - DEPARTMENT (IF APPLICABLE)	STORAGE ROOM
STORAGE - FM	STORAGE ROOM
STORAGE - TRAINING	STORAGE ROOM
STORAGE ROOM - DEPARTMENT (IF APPLICABLE)	STORAGE ROOM
STUDIO	STUDIO
TEAM HUDDLE	NO SIGN NEEDED
TOUCHDOWN	TOUCHDOWN
TRAINING - LG	TRAINING ROOM
TRAINING - LOCKERS	TRAINING ROOM
TRAINING - MD	TRAINING ROOM
TRAINING - SM	TRAINING ROOM
UTILITY	UTILITY ROOM
WAYSTATION	NO SIGN NEEDED
WELL CLINIC	NO SIGN NEEDED
WELLBEING	WELLBEING ROOM
WOMEN'S (UNLESS AHJ REQUIRES OTHERWISE)	WOMEN'S
WOMEN'S LOCKER ROOM	WOMEN'S LOCKER ROOM
WORK CAFÉ	WORK CAFÉ
WORKROOM	WORKROOM
MOBILE ELT	MOBILE OFFICE [AD-INT-OFFICE]
AUDIT ROOM	AUDIT ROOM
HUDDLE LOUNGE	HUDDLE ROOM
MOBILE OFFICE	MOBILE OFFICE [AD-INT-OFFICE]
MOBILE WORKSTATION	MOBILE WORKSTATION
WORKSTATION	AD-INT-WSR WITH INSERT

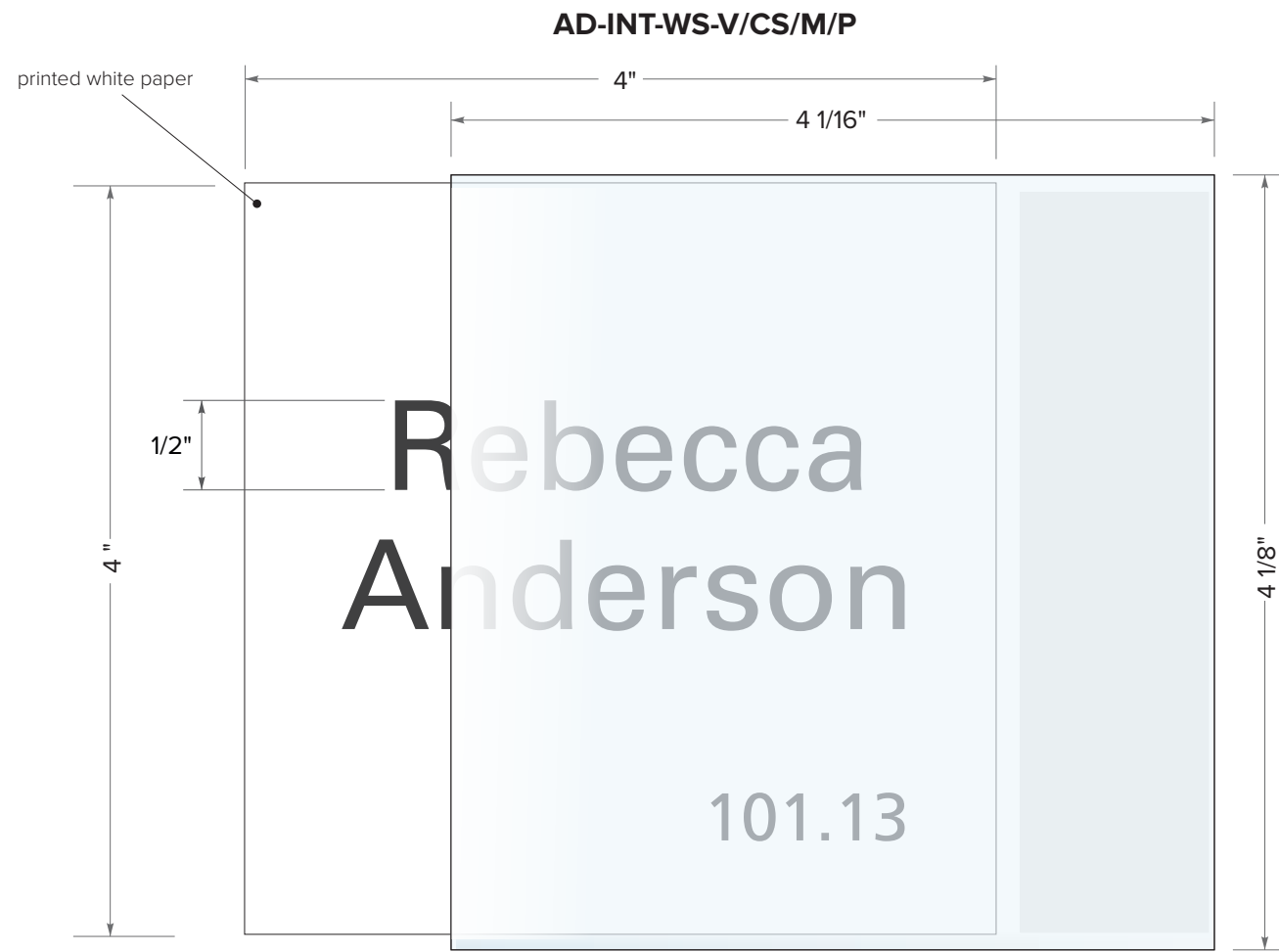

SCALE | 1:1

INSERT LAYOUTS

AD-WS-INSERT

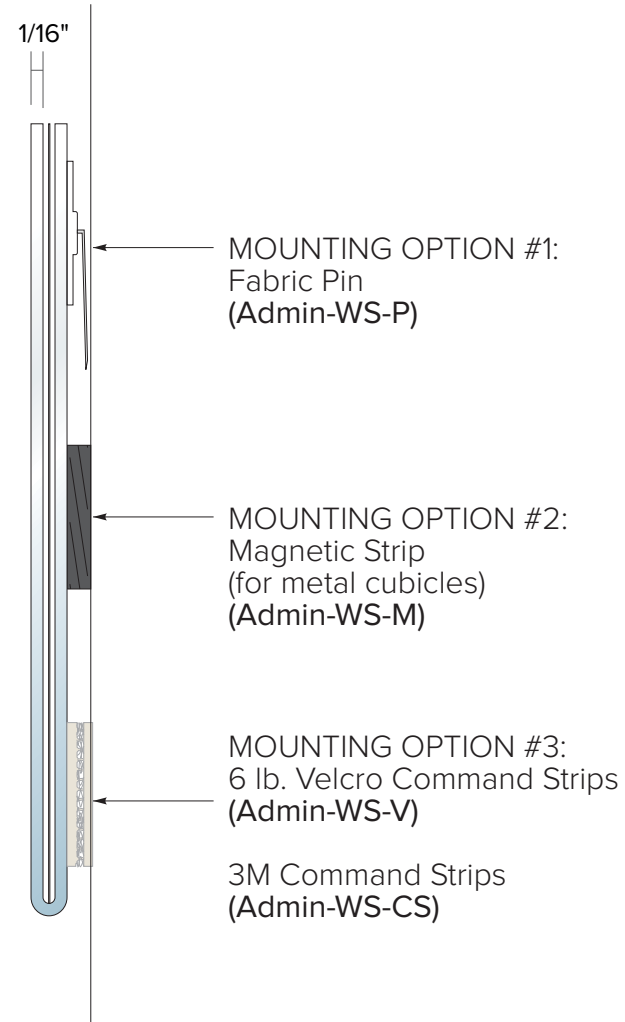
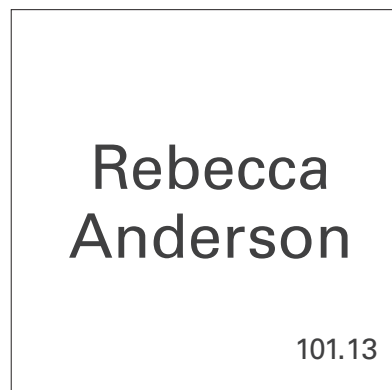

COLOR/ MATERIAL SPECIFICATIONS

- PANEL: 1/16" clear polycarbonate panel, heated formed to shape
- COPY: Cardstock paper insert with laser printed copy
**Inserts should list the "Employee Name" or "Mobile Desk" and the desk number.*
- FONT: Universe Lt Std Roman
- INSTALL: Vary per site

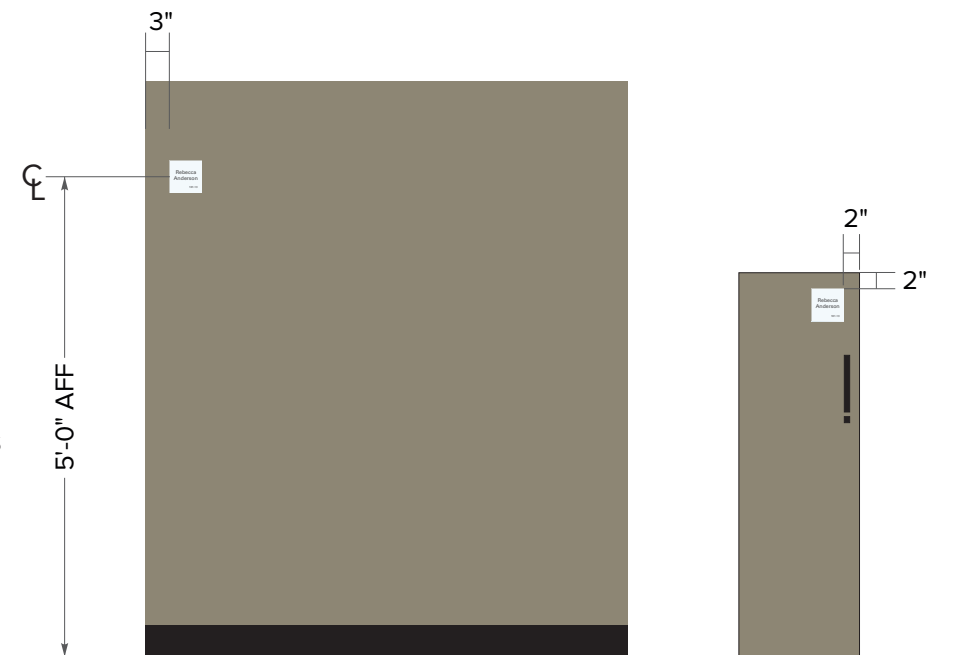

CUBICLE INSTALL (TYP.)
SCALE: 1/2" = 1'-0"

LOCKER INSTALL (TYP.)
SCALE: 1/2" = 1'-0"

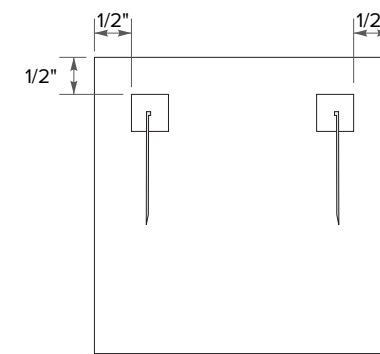

Fabric Pin Install

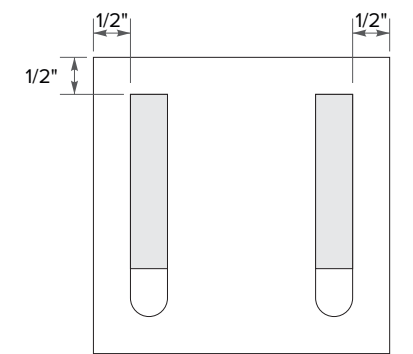

Velcro / 3M Command Strips Install

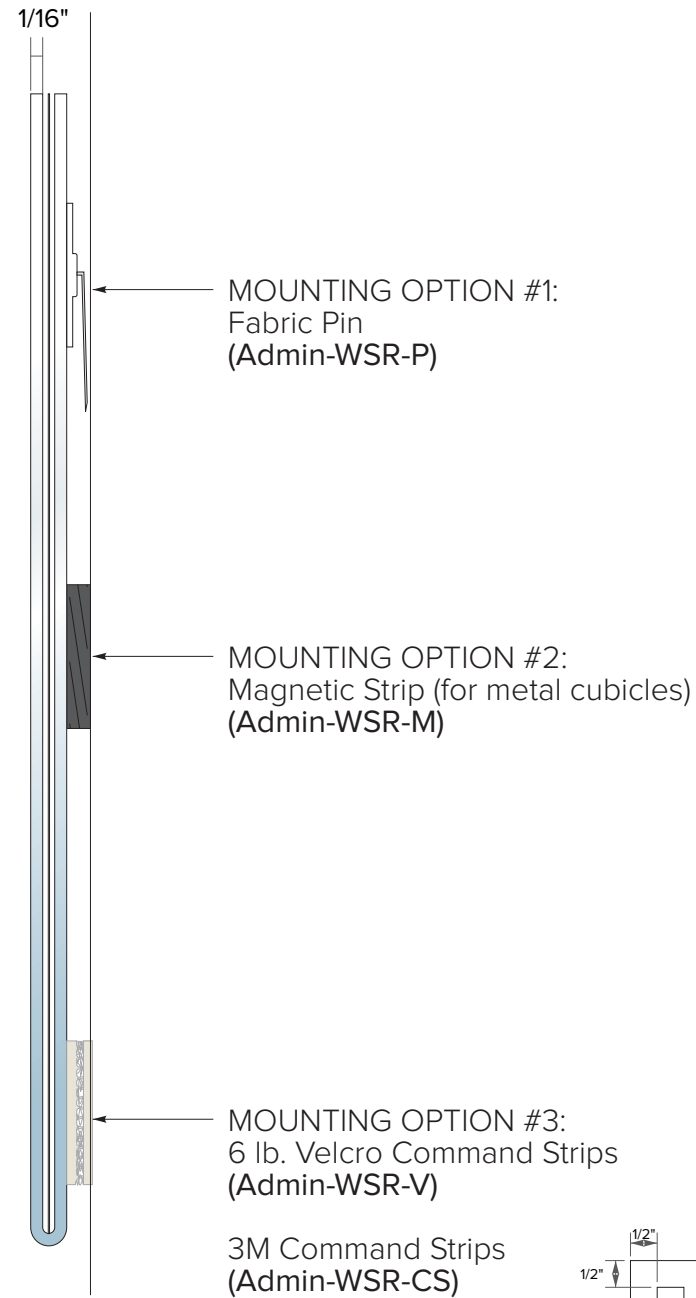
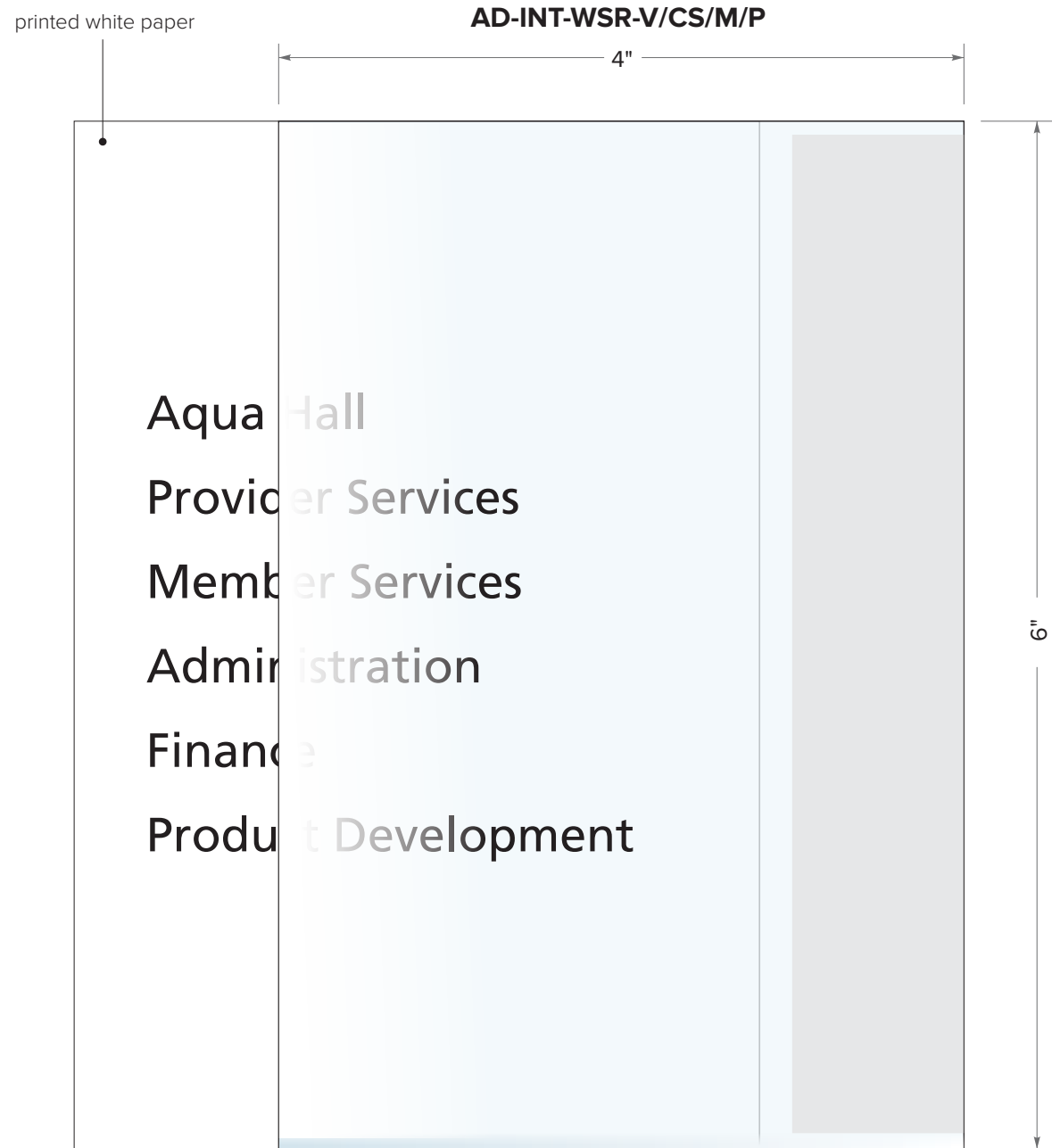

COLOR/ MATERIAL SPECIFICATIONS

- PANEL: 1/16" clear polycarbonate panel, heated formed to shape
- COPY: Cardstock paper insert with laser printed copy
- FONT: Universe Lt Std Roman
- INSTALL: Vary per site



TYPICAL INSTALL RENDERING AT AISLE SIDE OF PARTITION

SCALE | 1:1

AD-WSR-INSERT

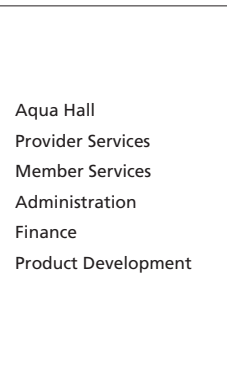

INSERT LAYOUTS

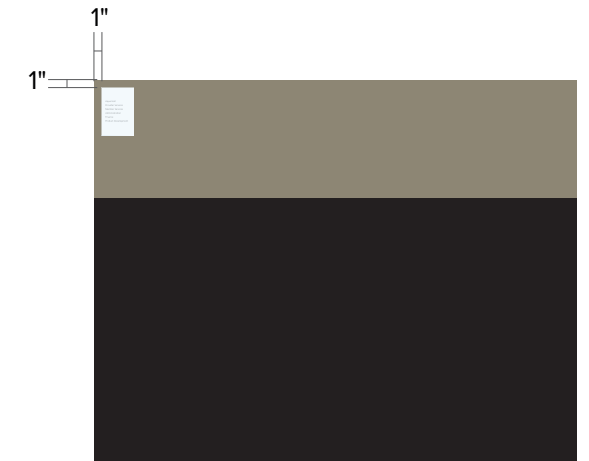
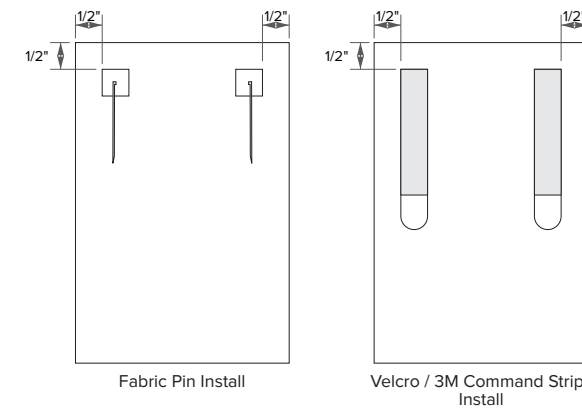

TYPICAL INSTALL
SCALE: 1/2" = 1'-0"



COLOR/ MATERIAL SPECIFICATIONS

- PANEL: 1/8" thick acrylic surface painted Akzo Nobel 493-A1 White, Matte finish
 - COPY/ICON: 1/32" raised tactile copy in Rowmark Charcoal Grey
- FONT: Frutiger Lt Std 55 Roman
- BRAILLE: Grade II - Clear Braille Rasters
- INSTALL: Install flush to wall with silicone and 3M 1/8" White Double-Faced Foam tape

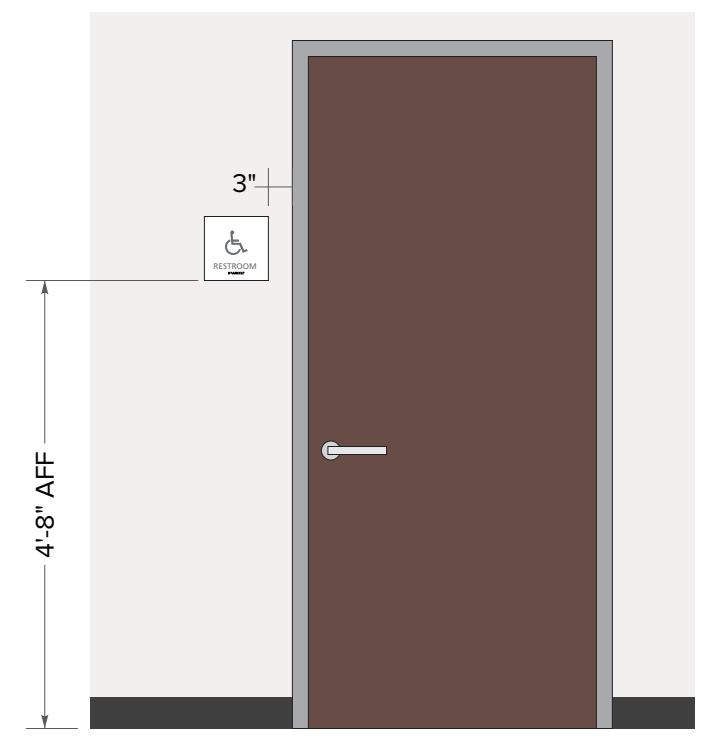

WALL MOUNT
SCALE: 1/2" = 1'-0"

SCALE | 1:2

Alternate Layouts



AD-INT-RR-D/WRR/DUS-CA (WHITE)

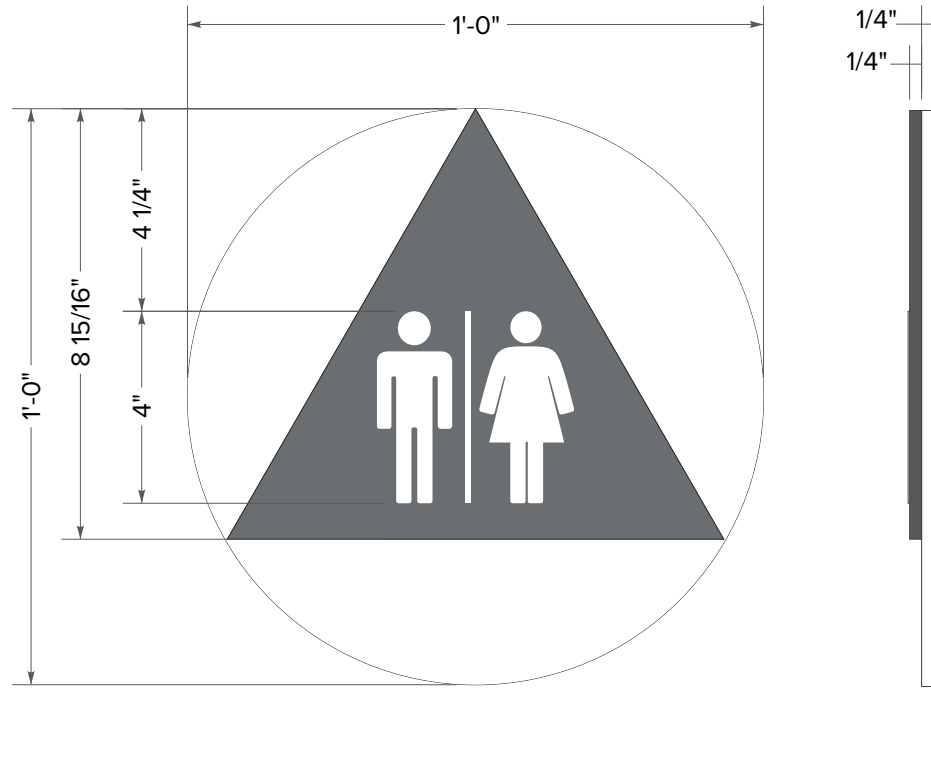

COLOR/ MATERIAL SPECIFICATIONS

- PANEL: Backer to be 1/4" thick acrylic surface painted Akzo Nobel 493-A1 White, Matte finish
Face panel to be 1/4" thick flat cut out acrylic triangle overlay painted Akzo Nobel 499-E5 Dark Gray, Matte finish
 - COPY/ICON: 1/32" raised tactile copy in Rowmark Charcoal Grey
- INSTALL: Install flush to wall with silicone and 3M 1/8" White Double-Faced Foam tape

NOTE: Door colors must be verified to determine backer & face colors. Backer must be a contrasting color from the door color.

AD-INT-RR-D/WRR/DUS-CA (GRAY)



COLOR/ MATERIAL SPECIFICATIONS

- PANEL: Backer to be 1/4" thick acrylic surface painted Akzo Nobel 499-E5 Dark Gray, Matte finish
Face panel to be 1/4" thick flat cut out acrylic triangle overlay painted Akzo Nobel 493-A1 White, Matte finish
 - COPY/ICON: 1/32" raised tactile copy in Rowmark White
- INSTALL: Install flush to wall with silicone and 3M 1/8" White Double-Faced Foam tape

Typical Dark Colored Door Elevation

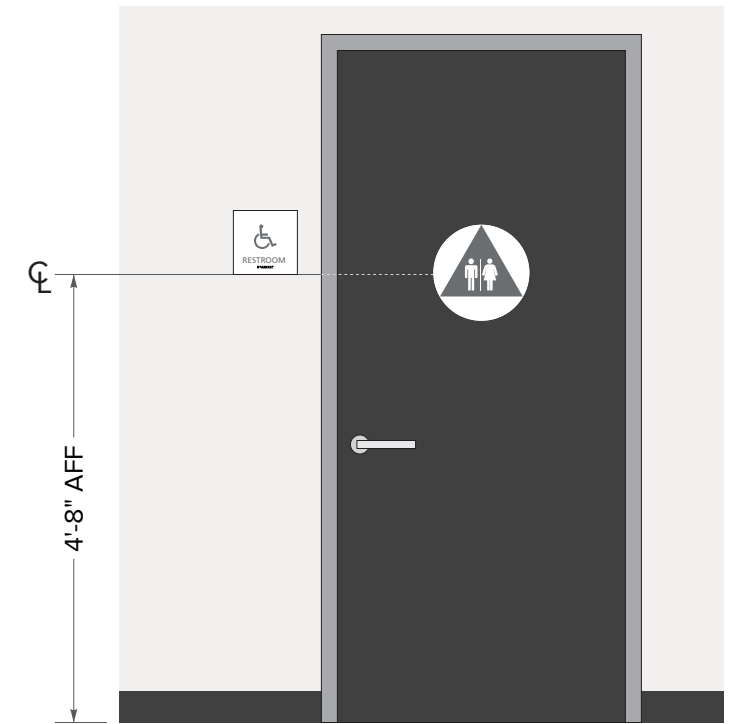

WALL MOUNT
SCALE: 1/2" = 1'-0"

Typical Light Colored Door Elevation

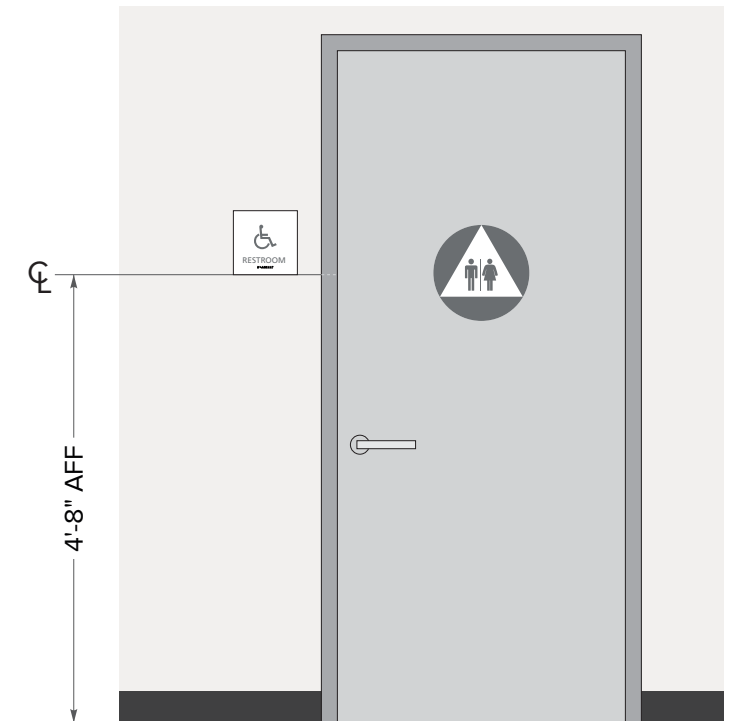

WALL MOUNT
SCALE: 1/2" = 1'-0"

SCALE | 1:4

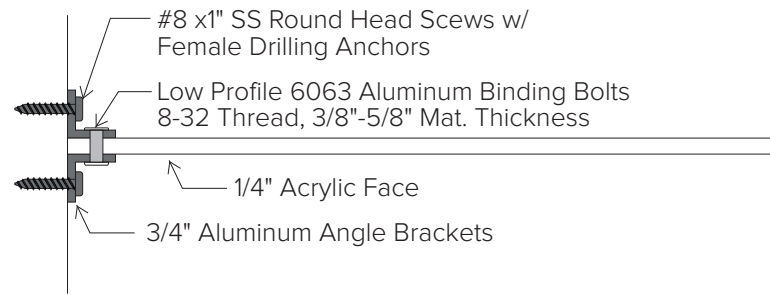

COLOR/ MATERIAL SPECIFICATIONS

- FACE PANEL: 1/4" acrylic panel with visible surfaces painted Akzo Nobel 493-A1 White, Matte finish
- MOUNTING BRACKET: 3/4" x 3/4" x 1/8" aluminum angle mounting brackets painted Akzo Nobel 499-E5 Dark Gray, Matte finish. Attach to face panel with low profile binding bolts with heads painted to match background.
- GRAPHICS: 3M #7725-41 Dark Grey vinyl

INSTALL: Install flush to wall surface with #8 round head screws and drilling anchors. Screw heads painted to match background.

AD-INT-RR-FM

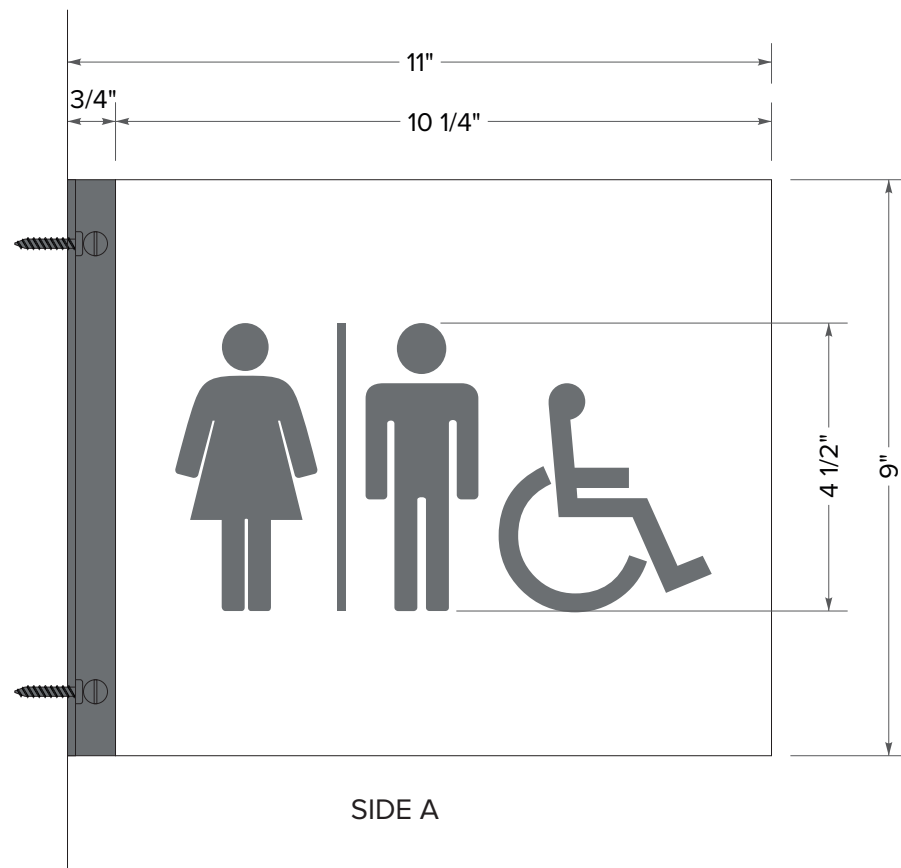

SCALE | 1:3

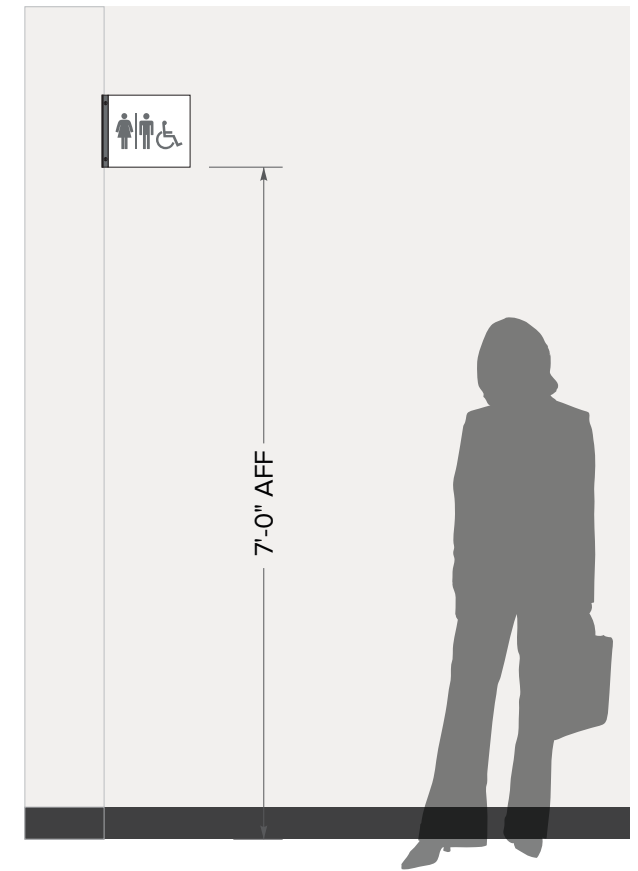
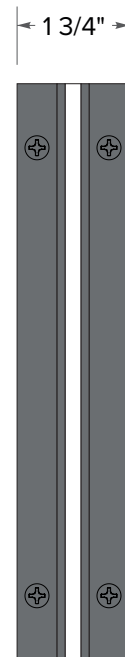

WALL MOUNT
 SCALE: 1/2" = 1'-0"

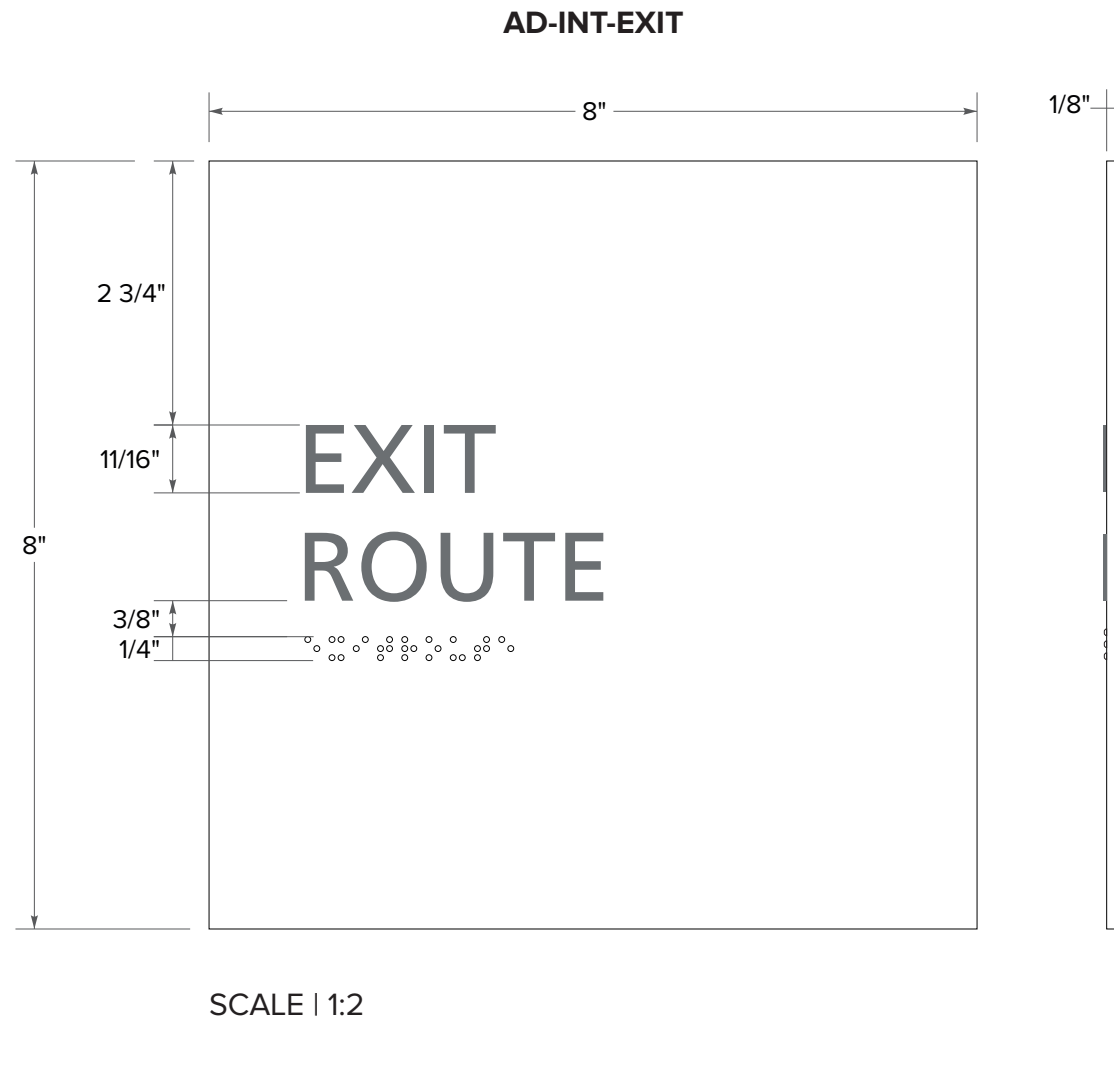

COLOR/ MATERIAL SPECIFICATIONS

- PANEL: 1/8" thick acrylic surface painted Akzo Nobel 493-A1 White, Matte finish
 - COPY/ICON: 1/32" raised tactile copy in Rowmark Charcoal Grey
- FONT: Frutiger Lt Std 55 Roman
- BRAILLE: Grade II - Clear Braille Rasters
- INSTALL: Install flush to wall with silicone and 3M 1/8" White Double-Faced Foam tape

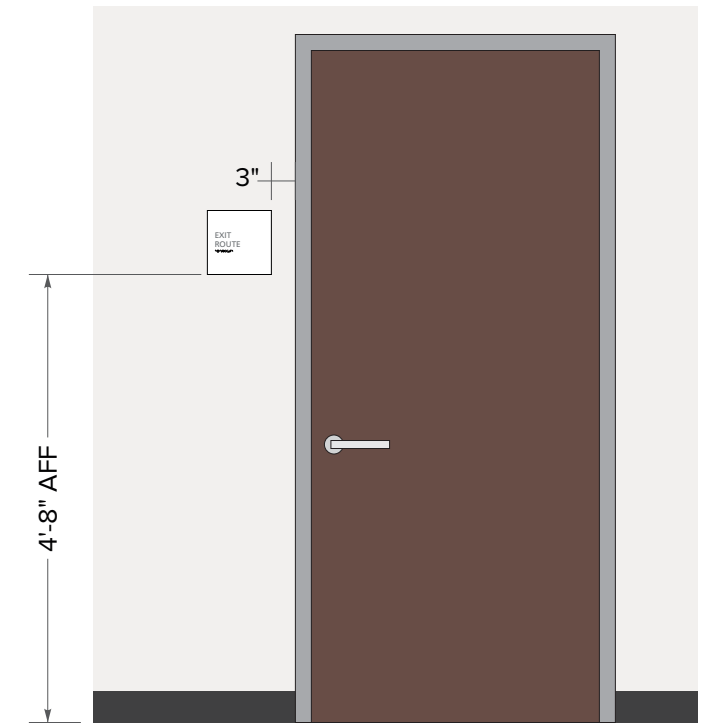

WALL MOUNT
SCALE: 1/2" = 1'-0"

Alternate Layouts

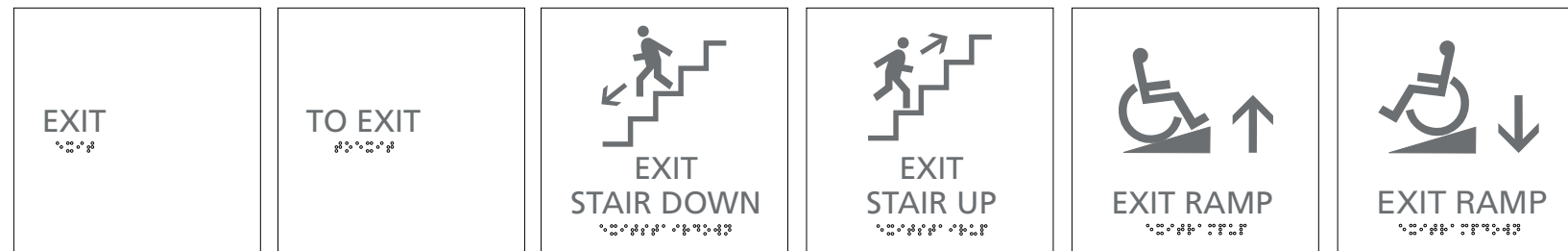

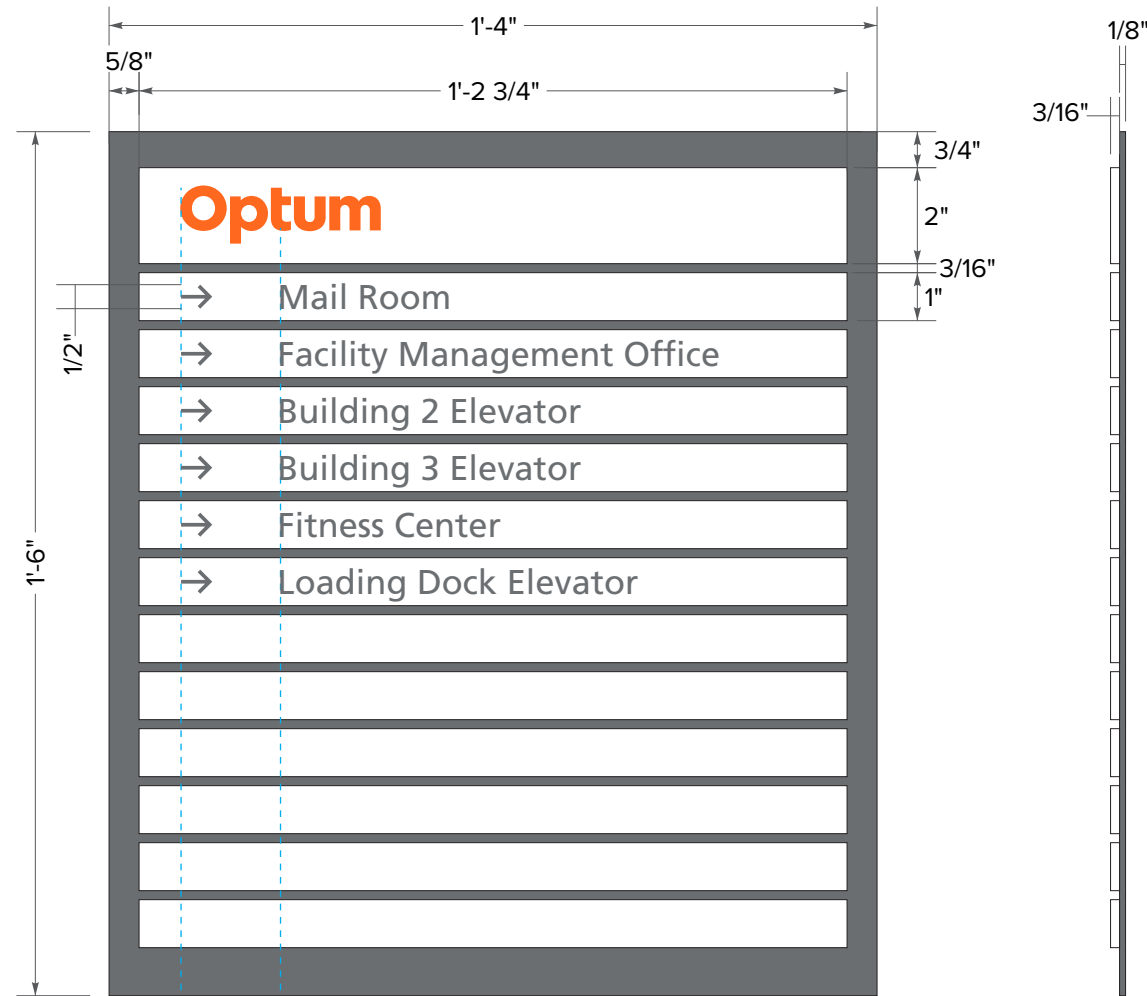

COLOR/ MATERIAL SPECIFICATIONS

- PANEL: Backer panel to be 1/8" thick aluminum panel painted Akzo Nobel 499-E5 Dark Gray, Matte finish;
 - Directory panels to be 3/16" opaque #7508 white acrylic
- COPY: Surface applied 3M #7725-41 Dark Grey vinyl
- LOGOS: Optum - 3M #180mc-3289 Opaque Orange vinyl
 - UHC / UHG -3M #7725-37 Sapphire Blue vinyl

FONT: Frutiger Lt Std 55 Roman

BRAILLE: Grade II - Clear Braille Rasters

INSTALL: Install flush to wall with silicone and 3M 1/8" White Double-Faced Foam tape

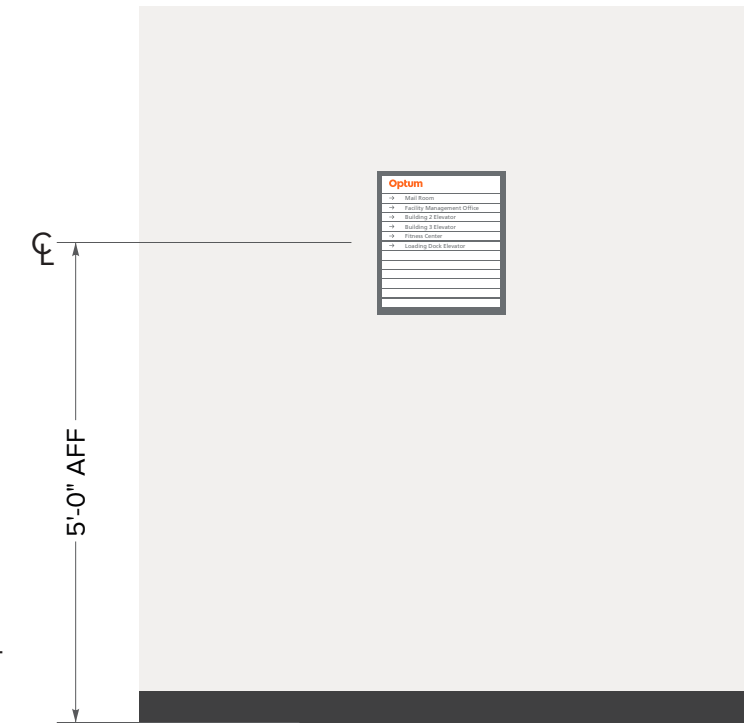

WALL MOUNT
SCALE: 1/2" = 1'-0"

Alternate Layouts

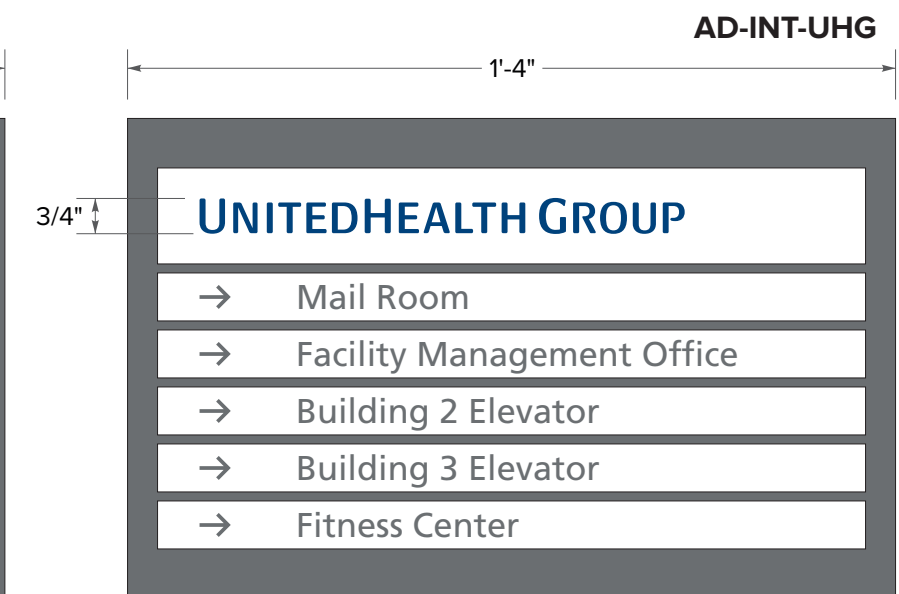
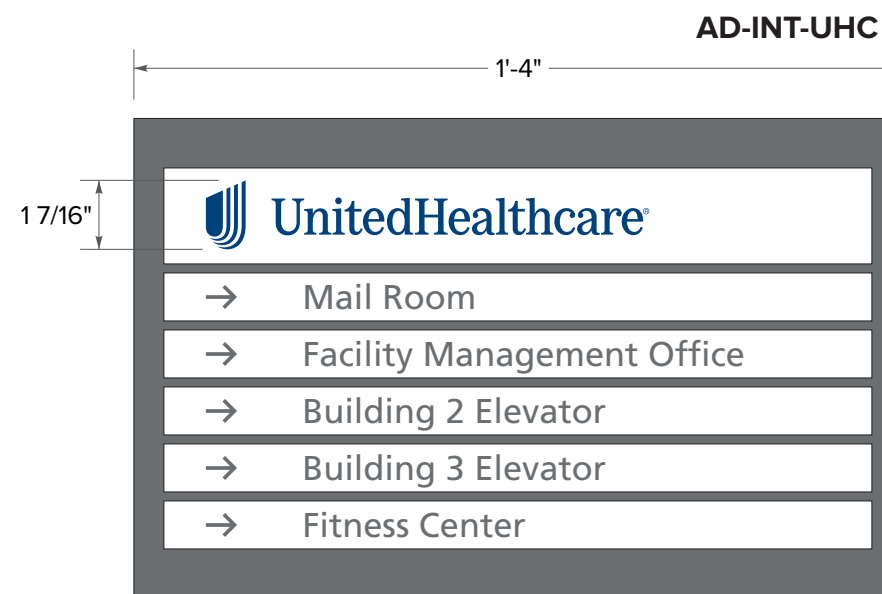
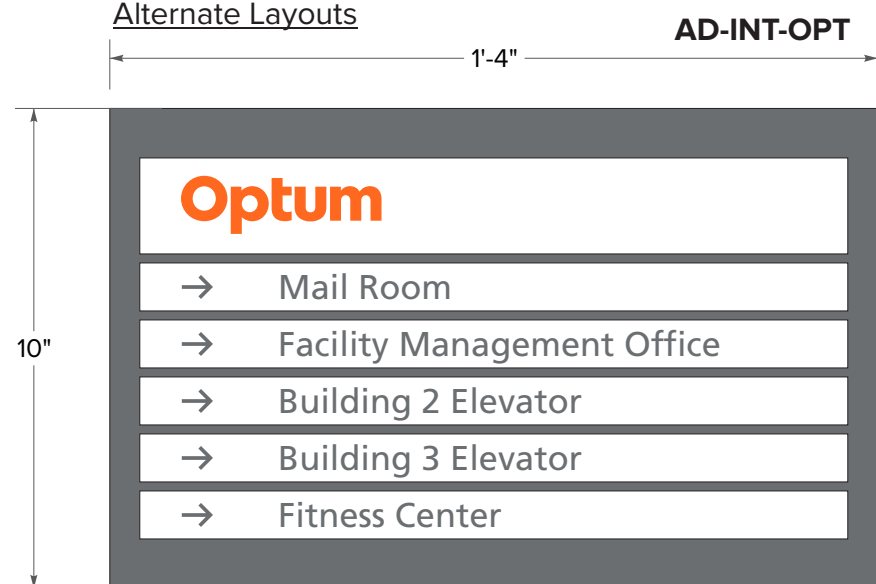

SCALE | 1:4

COLOR/ MATERIAL SPECIFICATIONS

□ PANEL: 1/16" clear polycarbonate panel, heated formed to shape

COPY: Paper insert with laser printed copy

FONT: Universe LT Std Roman

INSTALL: Standard - Option A: Install via Velcro adhesive strips as needed (Admin-Holder-11x17-V)
 Standard - Option B - Install via 3M Command Strips as needed (Admin-Holder-11x17-CS)
 Metal Cubical: Install via 1/8" magnetic strips as needed (Admin-Holder-11x17-<)
 Fabric Cubical: Install via fabric pins as needed (Admin-Holder-11x17-P)

AD-INT-HOLDER-11X17-V/CS/M/P

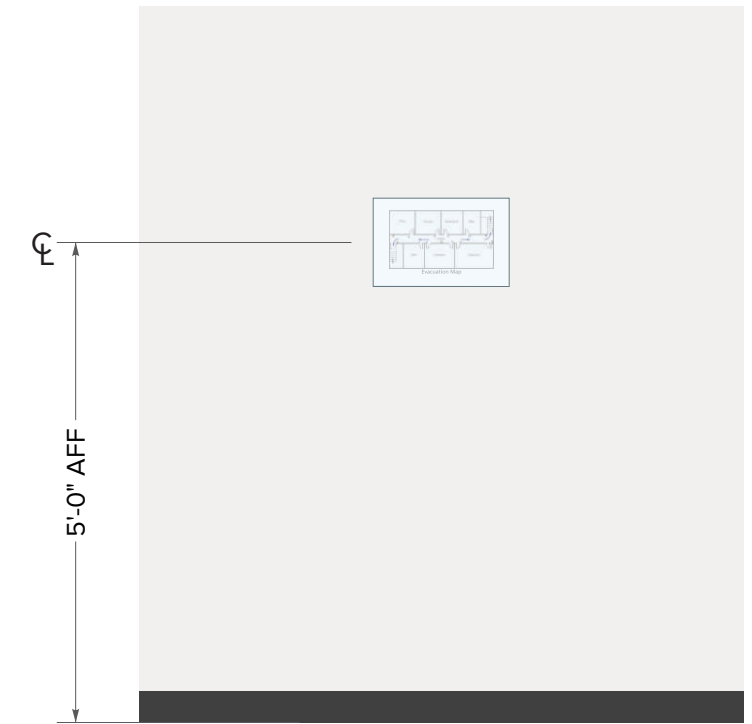
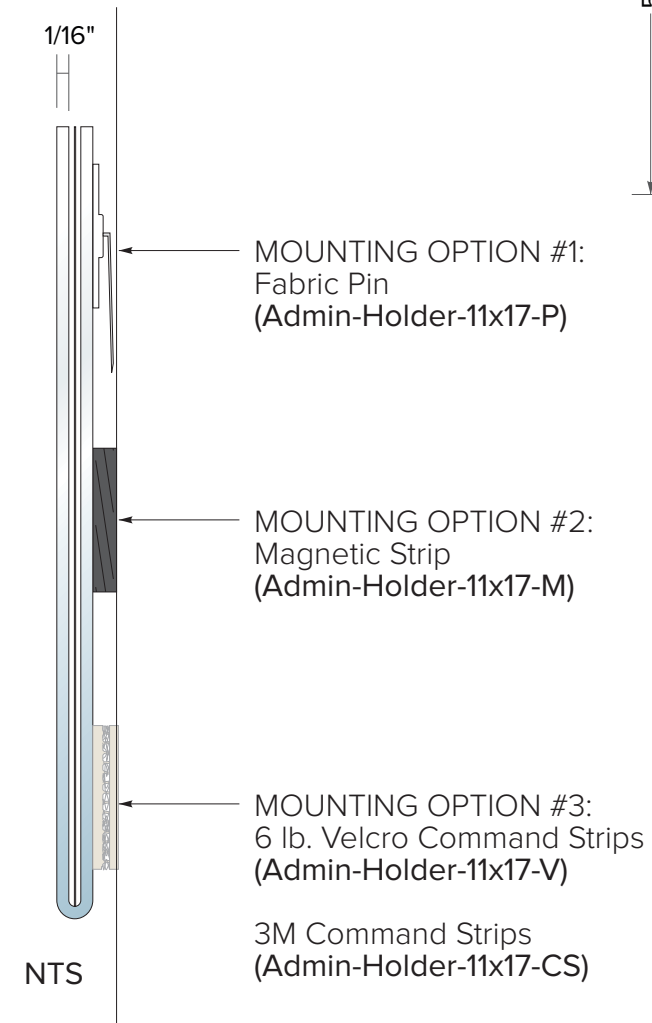
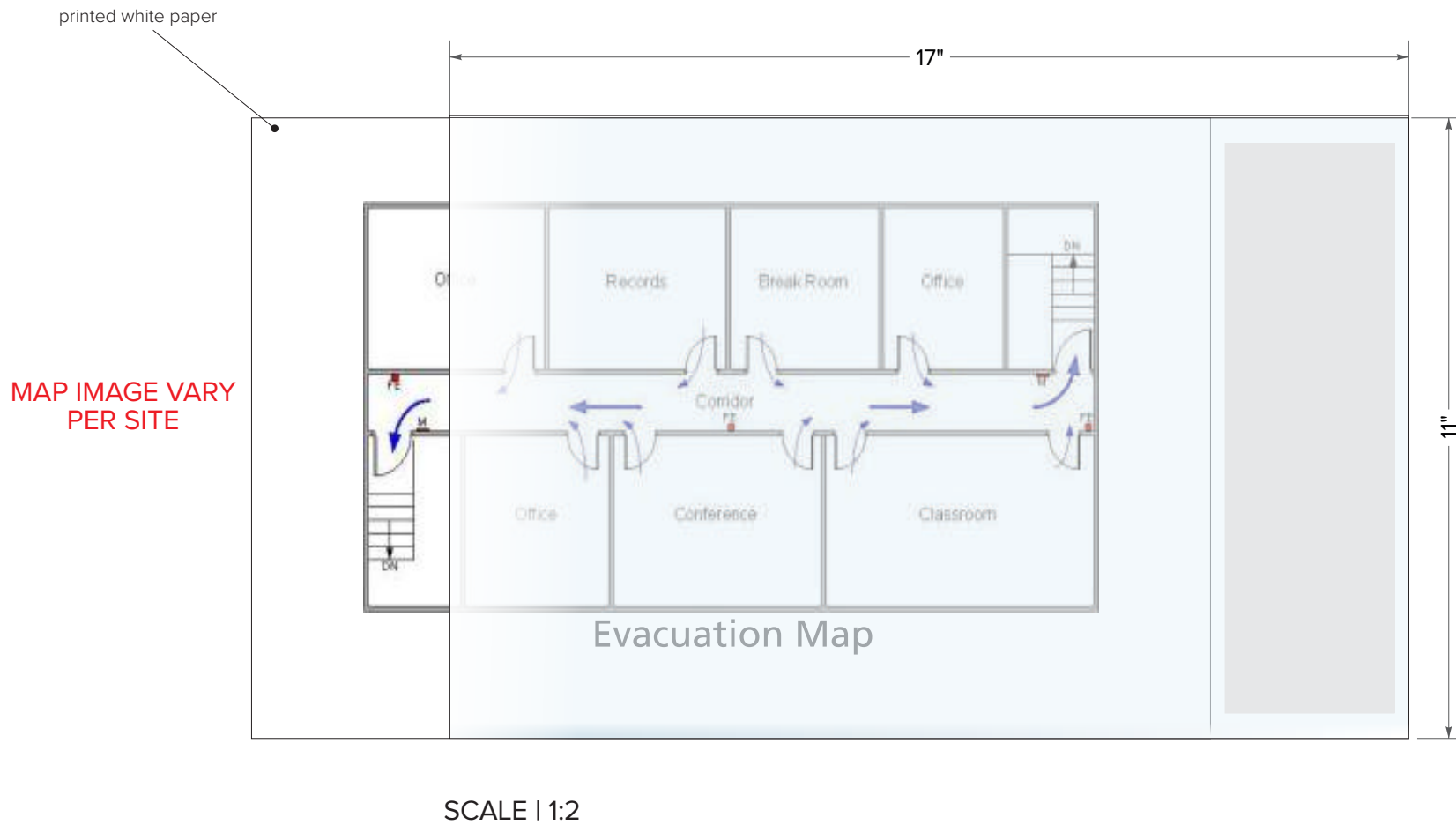

AD-INT-HOLDER-11X8.5-V/CS/M/P

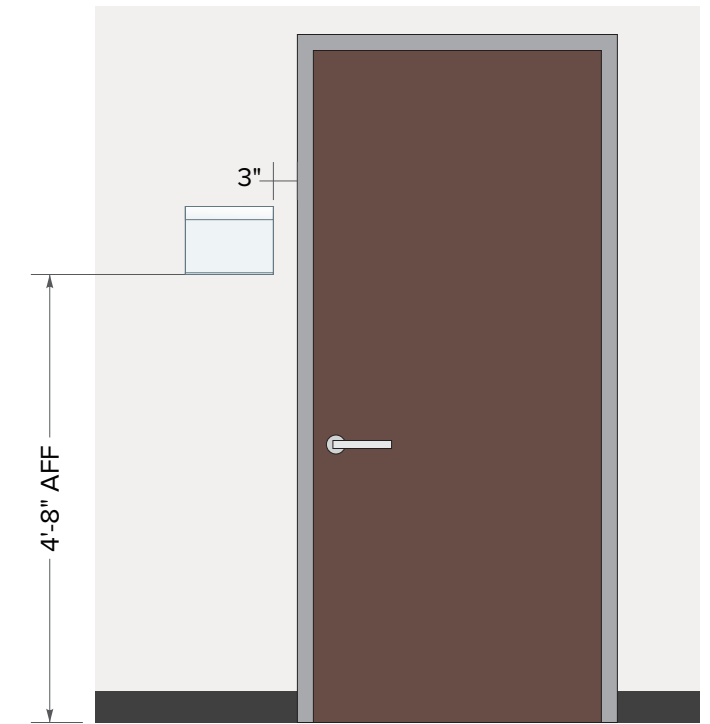
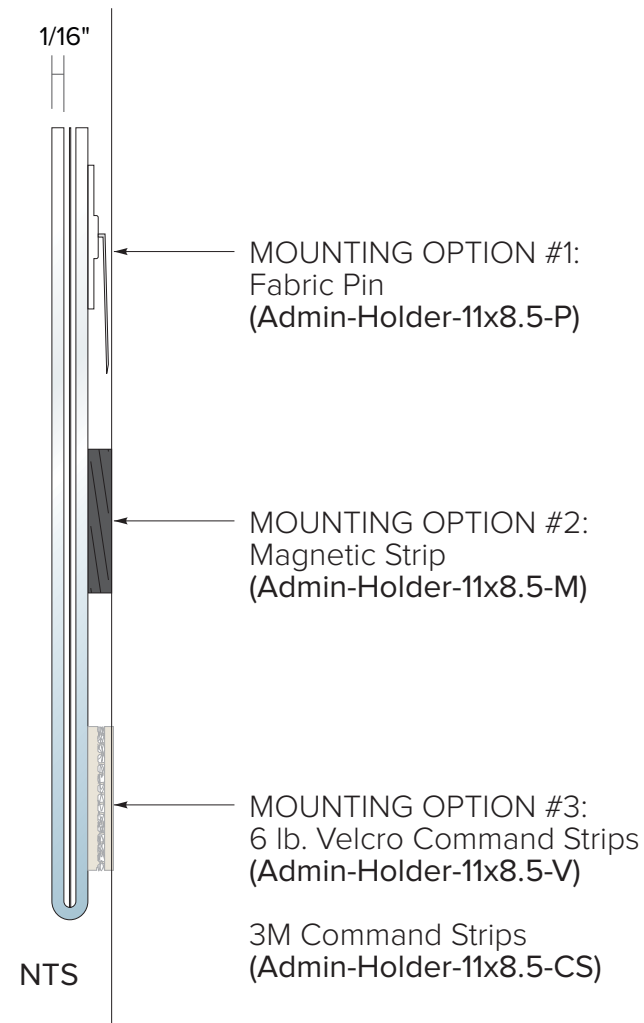
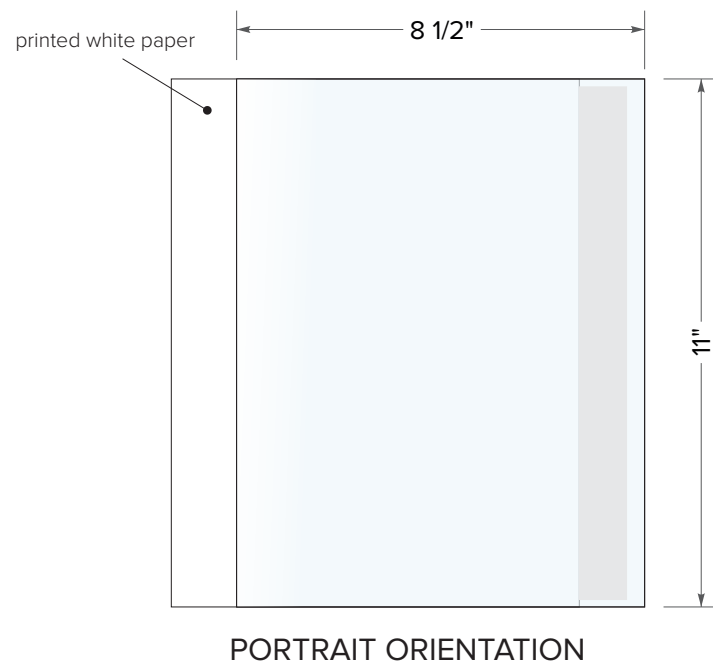
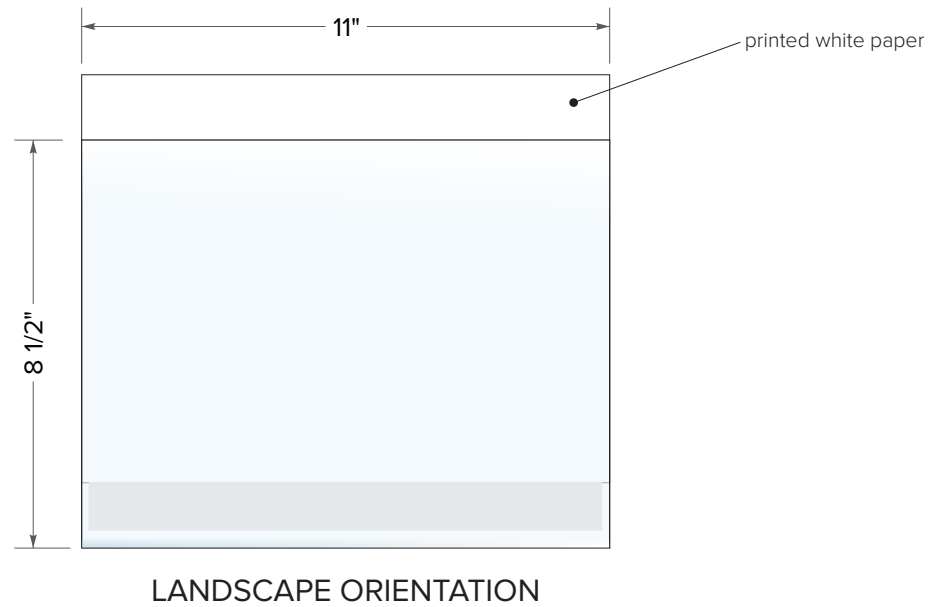

WALL MOUNT
SCALE: 1/2" = 1'-0"

COLOR/ MATERIAL SPECIFICATIONS

- PANEL: 1/16" clear polycarbonate panel, heated formed to shape
- COPY: Paper insert with laser printed copy
- INSTALL: Vary per site

SCALE | 1:2

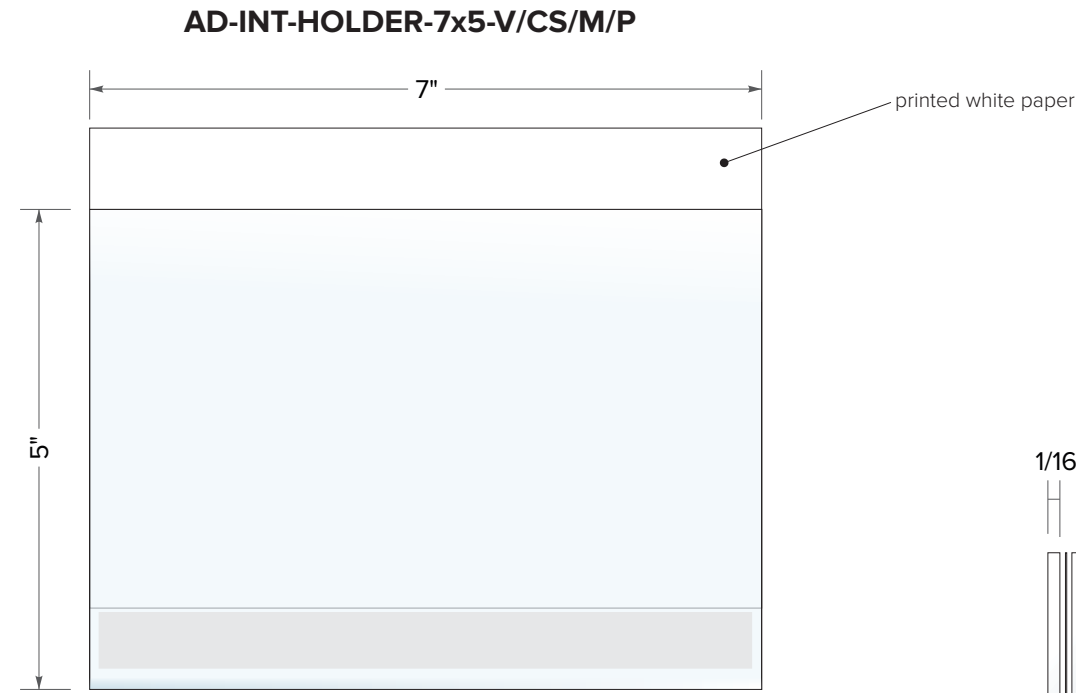

LANDSCAPE ORIENTATION

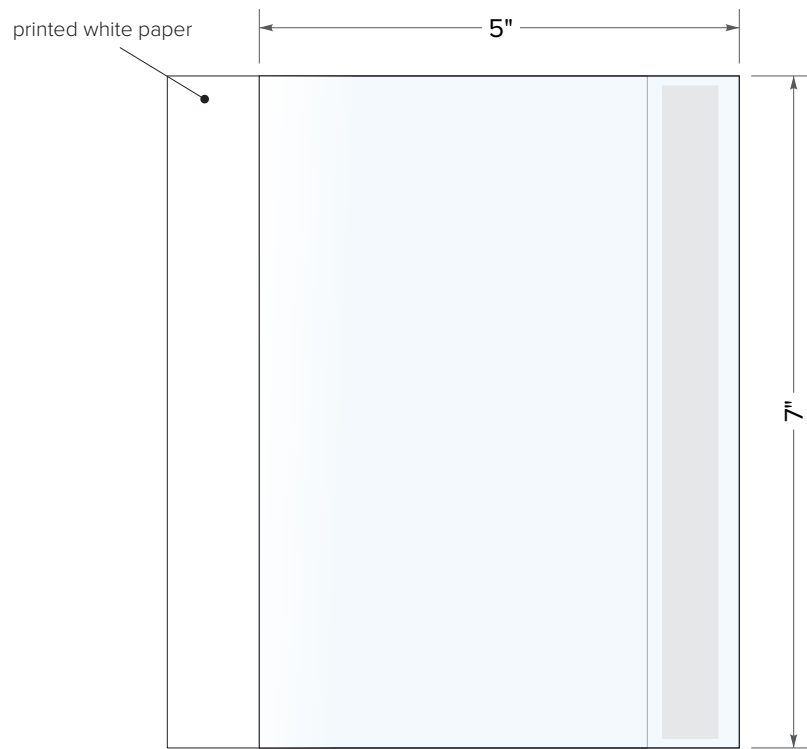

PORTRAIT ORIENTATION

SCALE | 1:2

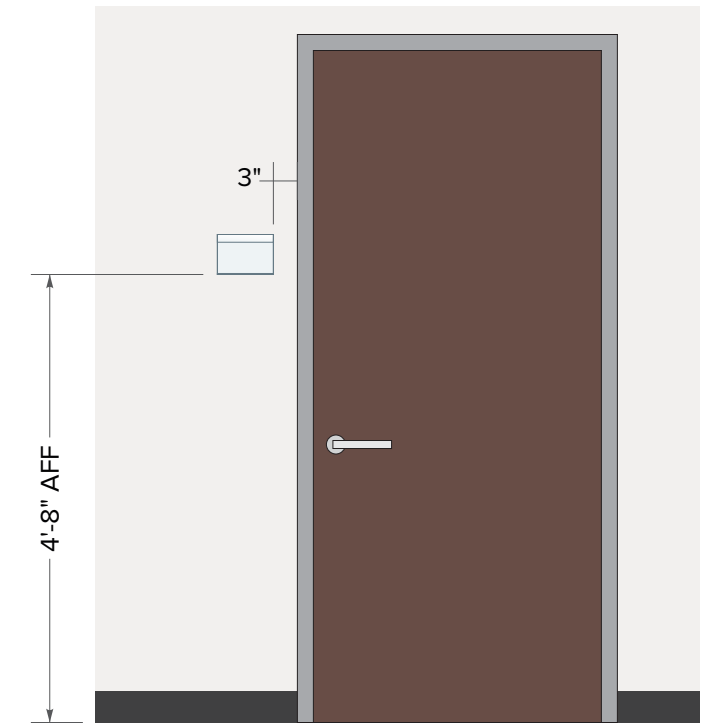
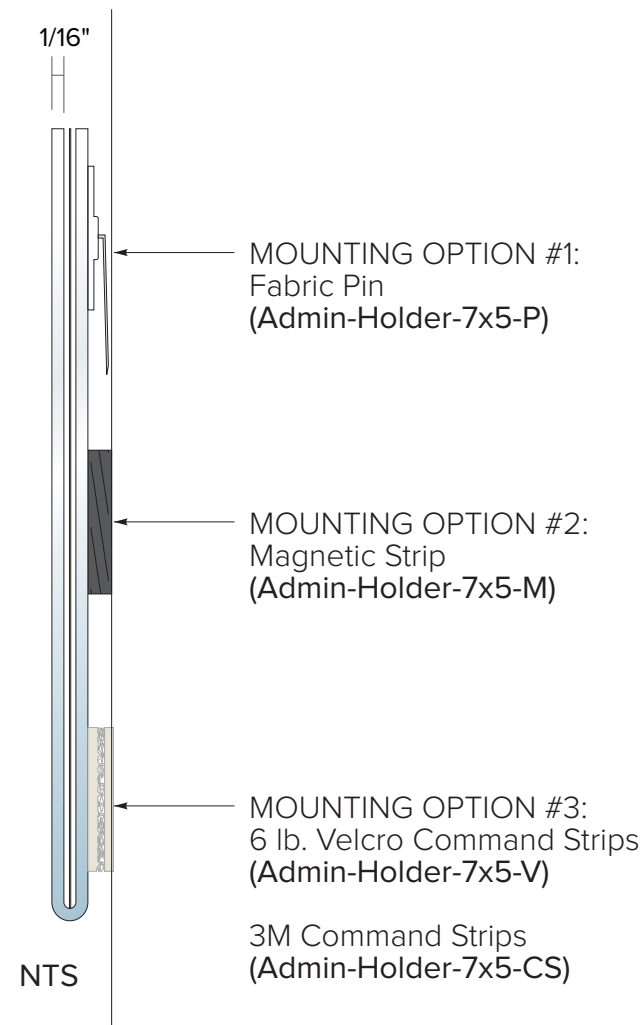

WALL MOUNT
SCALE: 1/2" = 1'-0"

COLOR/ MATERIAL SPECIFICATIONS

- PANEL: 1/16" clear polycarbonate panel, heated formed to shape
- COPY: Paper insert with laser printed copy
- INSTALL: Vary per site

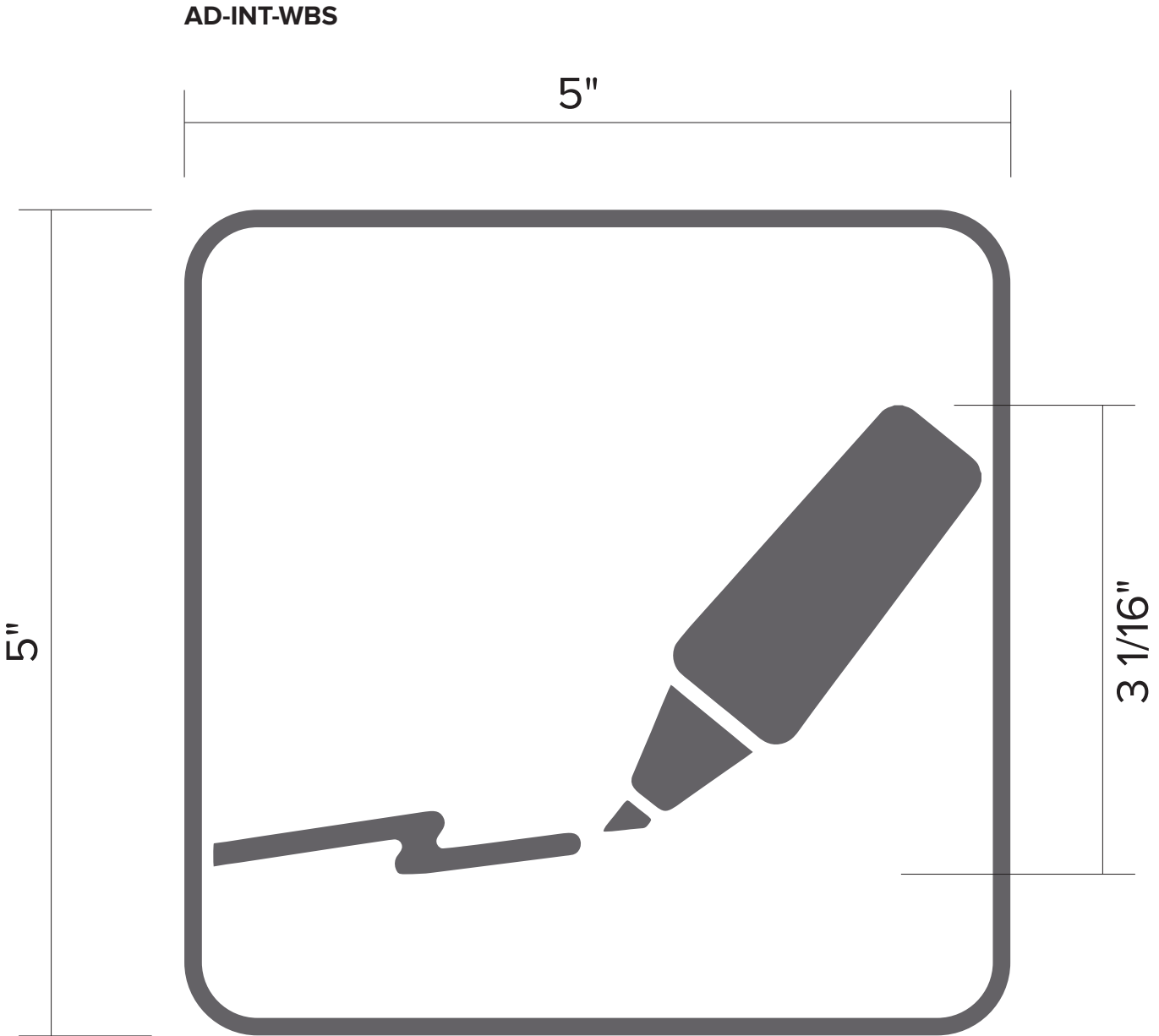

COLOR/ MATERIAL SPECIFICATIONS

- GRAPHICS: Digitally printed vinyl to match PMS Cool Gray 11C

AD-INT-MAIL-1



COLOR/ MATERIAL SPECIFICATIONS

- PANEL: 1/8" acrylic face painted Akzo Nobel 493-A1 White, Matte finish
- COPY: 1/32" raised tactile copy in Rowmark Charcoal Grey;
 - Accent lines to be 3M #7725-41 Dark Grey vinyl

FONT: Arial Regular

INSTALL: Mail sign mounted flush to wall with 3M RP45 VHB tape and silicone.
Incoming and Outgoing signs mounted to wire baskets with zip ties.

AD-INT-MAIL-2



SCALE | 1:2

Waste Sort Signage Standards

USED ON PANTRY AREAS

G/C/O-ST-REC



USED ON WAYSTATION AREAS

G/C/O-ST-REC (ICON)

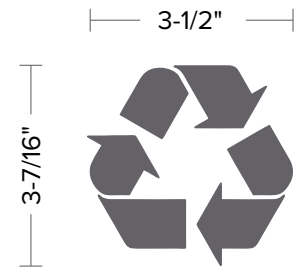

USED ON PANTRY AREAS

G/C/O-ST-REC

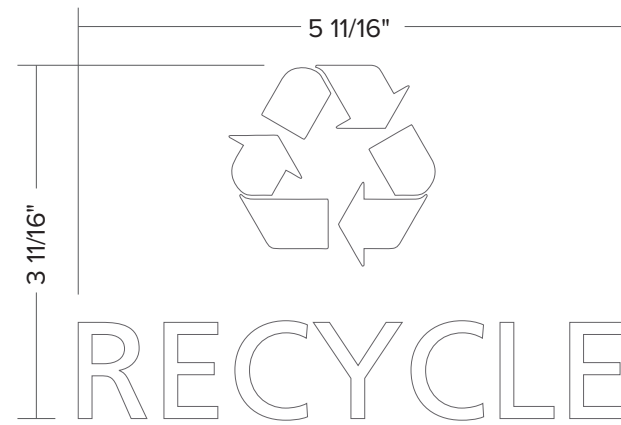

USED ON WAYSTATION AREAS

G/C/O-ST-REC (ICON)

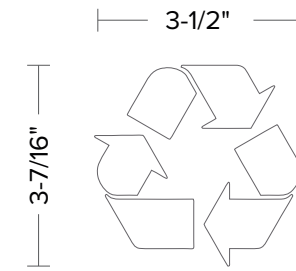

G/C/O-ST-TO



G/C/O-ST-WASTE

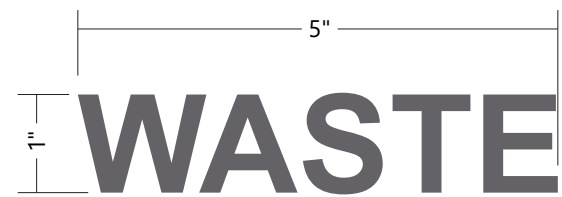

G/C/O-ST-TO



G/C/O-ST-WASTE

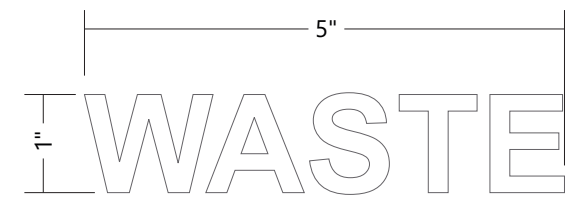

AD-INT-VIN-ORGN



TYPICAL EXISTING SIGNAGE



AD-INT-VIN-ORGN

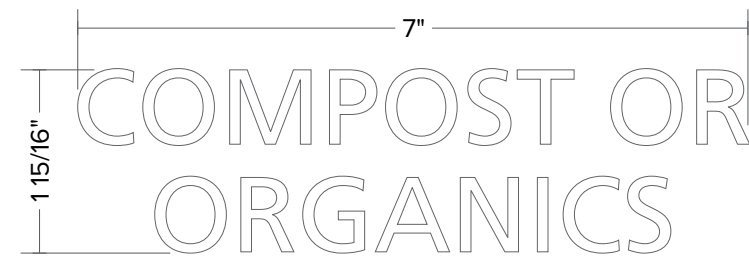

COLOR/ MATERIAL SPECIFICATIONS

■ GRAPHICS: Digitally printed vinyl to match PMS Cool Gray 11C

COLOR/ MATERIAL SPECIFICATIONS

□ GRAPHICS: 3M #7725-20 Matte White vinyl

SCALE | 1:2

COLOR/ MATERIAL SPECIFICATIONS

MATERIAL: Digitally printed 6mil white vinyl w/ repositionable adhesive

LAMINATE: 3mil matte laminate

FONT: Optum Sans XBold

PROPOSED PLACEMENT

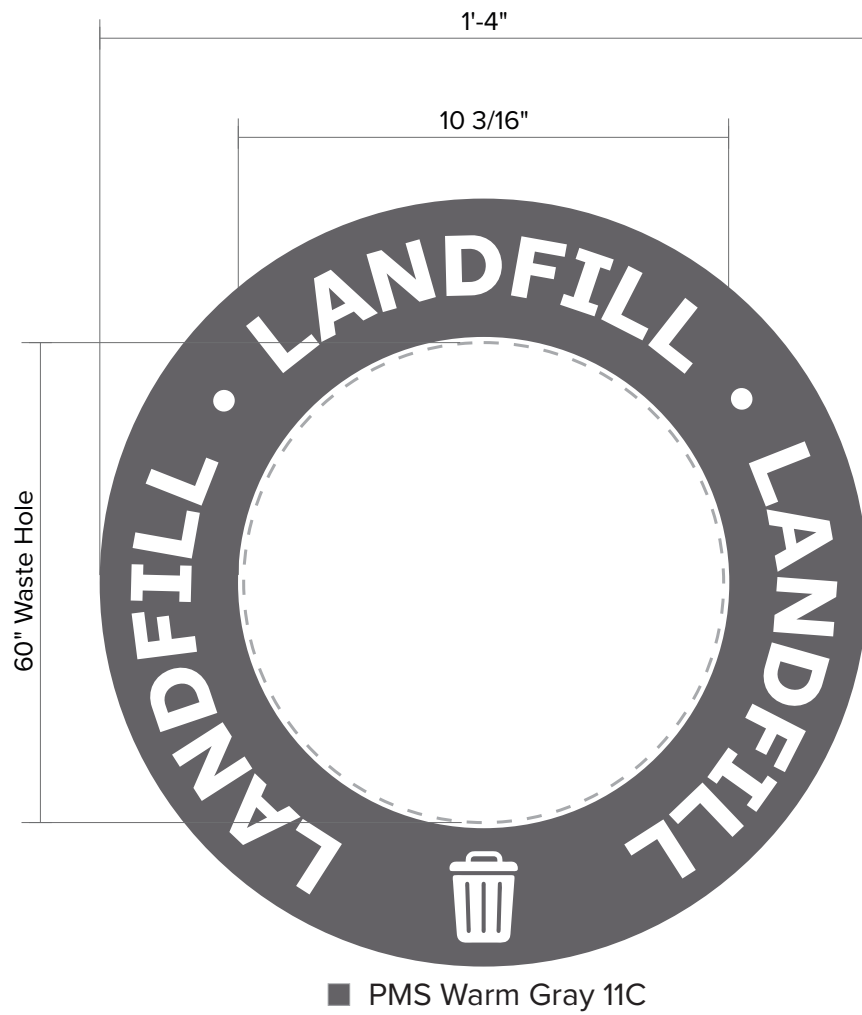
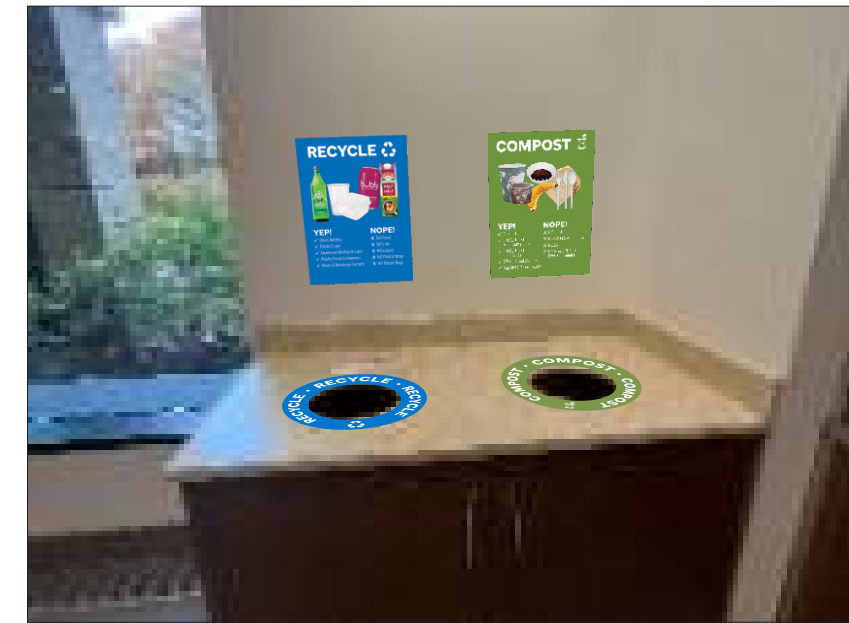

COLOR/ MATERIAL SPECIFICATIONS

MATERIAL: Digitally printed 6mil white vinyl
w/ repositionable adhesive

LAMINATE: 3mil matte laminate

FONT: Optum Sans XBold

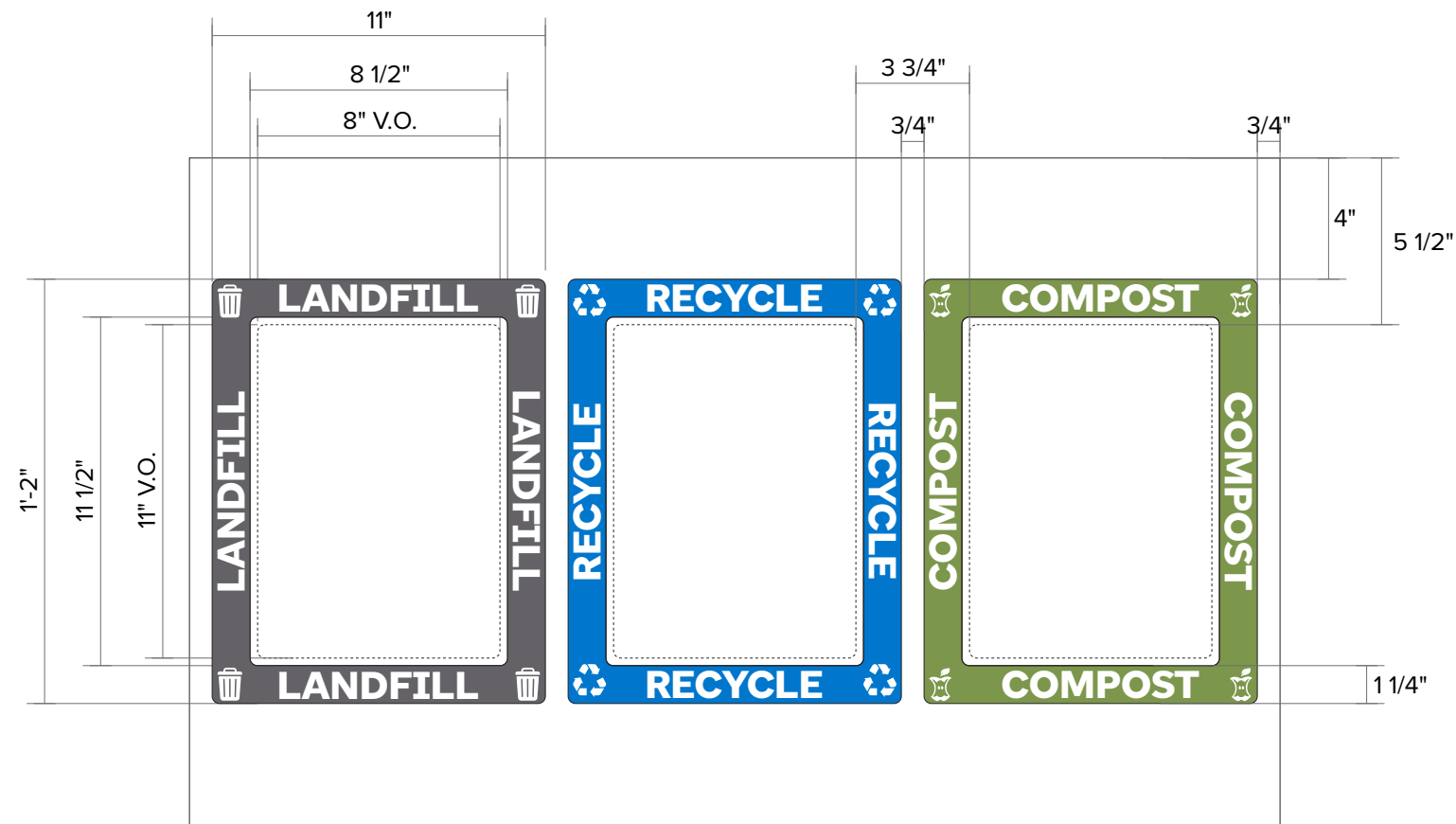

TOP VIEW
scale | 1:6

PROPOSED PLACEMENT



COLOR/MATERIAL SPECIFICATIONS

- Panel: 1/16" Clear polycarbonate panel, heated formed to shape
- PMS Warm Gray 11C
- Copy: Paper insert with laser printed copy
- PMS 2174c
- FONT: **Optum Sans XBold**
- PMS 7490c
- Optum Sans Regular
- INSTALL: 3M Double Sided Tape

PROPOSED PLACEMENT

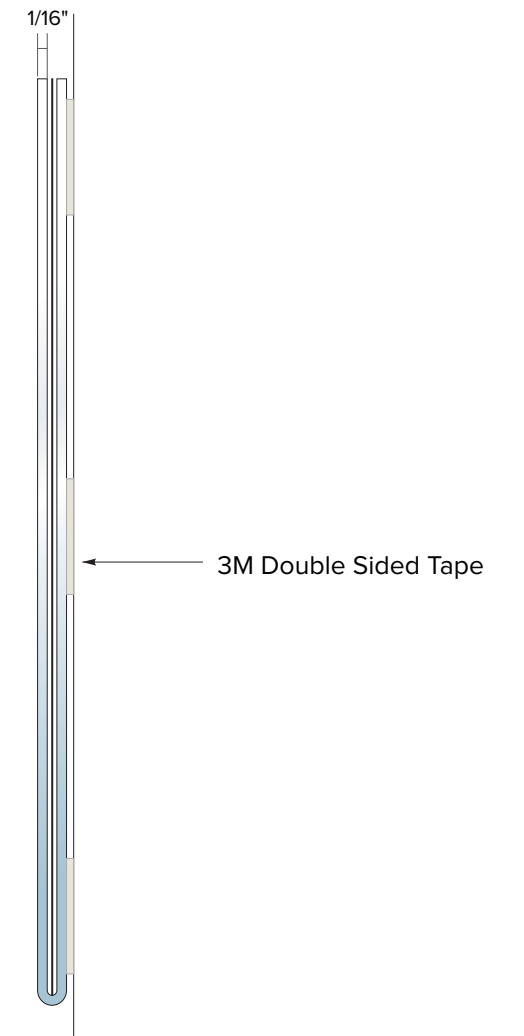
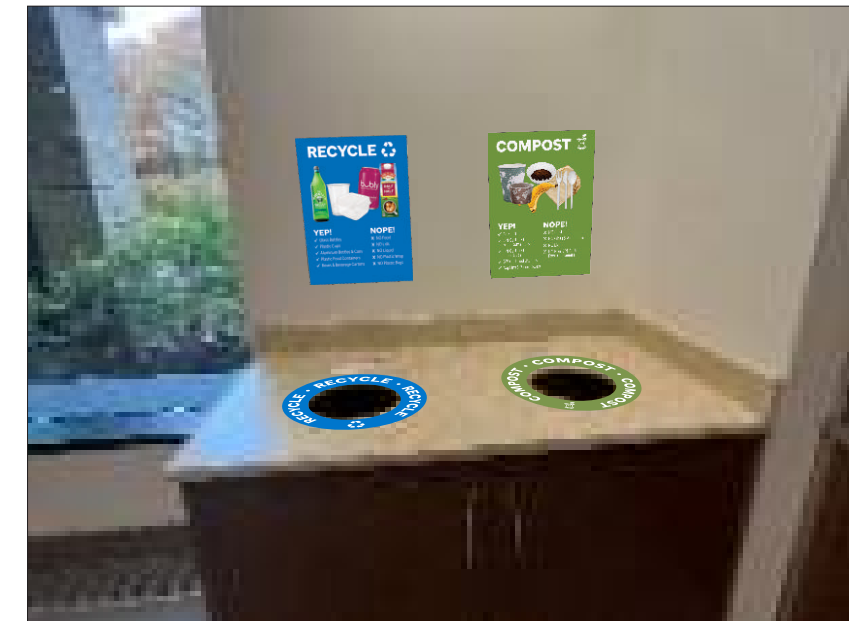

AD-INT-WP-ACRYLIC



COLOR/ MATERIAL SPECIFICATIONS

MATERIAL: Digitally printed 6mil white vinyl w/ repositionable adhesive

LAMINATE: 3mil matte laminate

FONT: **Optum Sans XBold**
Optum Sans Regular

- PMS Warm Gray 11C
- PMS 2174c
- PMS 7490c

PROPOSED PLACEMENT



1'-2"

COMPOST

1'-7"

<p>YEP!</p> <ul style="list-style-type: none"> ✓ All Food ✓ BPI Certified Food Containers ✓ BPI Certified Paper Cups ✓ BPI Certified Utensils ✓ Napkins & Paper Towels 	<p>NOPE!</p> <ul style="list-style-type: none"> ✗ NO Plastic ✗ NO Glass & Aluminum ✗ NO Liquid ✗ NO Non-BPI Certified Food Containers
--	--

RECYCLE

<p>YEP!</p> <ul style="list-style-type: none"> ✓ Glass Bottles ✓ Plastic Cups ✓ Aluminum Bottles & Cans ✓ Plastic Food Containers ✓ Boxes & Beverage Cartons 	<p>NOPE!</p> <ul style="list-style-type: none"> ✗ NO Food ✗ NO Lids ✗ NO Liquid ✗ NO Plastic Wrap ✗ NO Plastic Bags
--	---

LANDFILL

<p>YEP!</p> <ul style="list-style-type: none"> ✓ Plastic Bags ✓ Plastic Wrap ✓ Plastic Wrappers ✓ Lids & Caps 	<p>NOPE!</p> <ul style="list-style-type: none"> ✗ NO Food ✗ NO Liquid ✗ NO Glass & Aluminum
--	---

WHEN IN DOUBT, THROW IT OUT

AD-INT-WP-DP
scale | 1:4



COLOR/ MATERIAL SPECIFICATIONS

MATERIAL: Digitally printed 6mil white vinyl
w/ repositionable adhesive

LAMINATE: 3mil matte laminate

FONT: Optum Sans XBold

■ PMS Warm Gray 11C

■ PMS 2174c

■ PMS 7490c

PROPOSED PLACEMENT



AD-INT-WVGRPHC
scale | 1:2

Legacy Signage Standards

To be used when matching existing Legacy signage at a location. Preferred approach is to update to current standards when able.

COLOR/ MATERIAL SPECIFICATIONS

- FCO: 1/4" flat cut out aluminum logo
 - Paint to match 3M #7725-31 Medium gray and
 - 3M #7725-14 Bright Orange.
 - All finishes to be matte.

INSTALL: Stud mount flush to interior wall

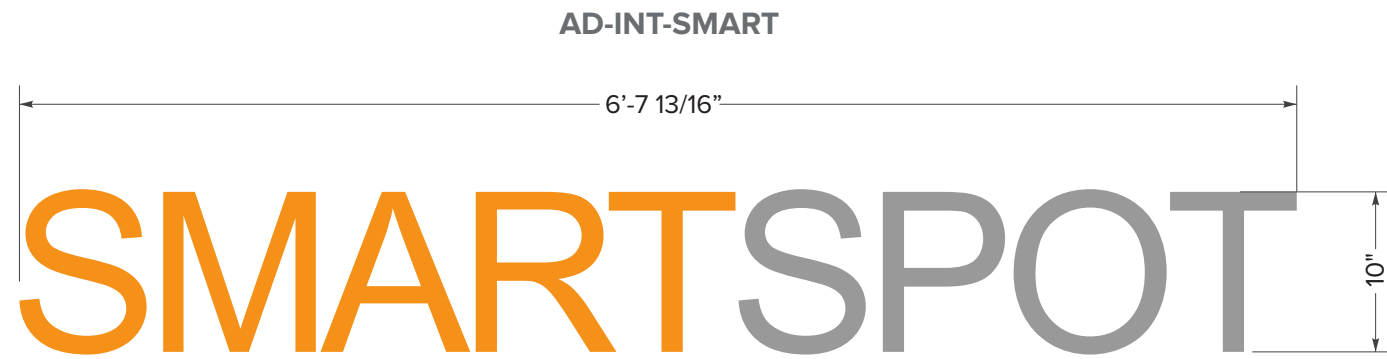

SCALE: 1" = 1'-0"



SCALE: 1/2" = 1'-0"

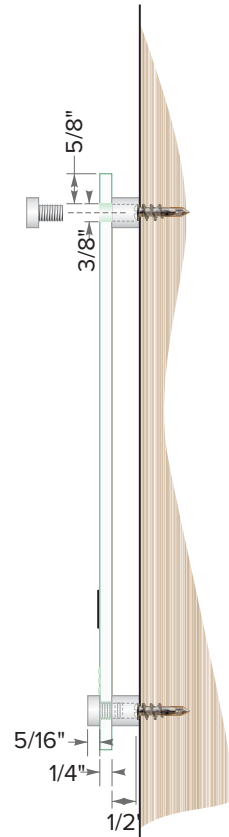
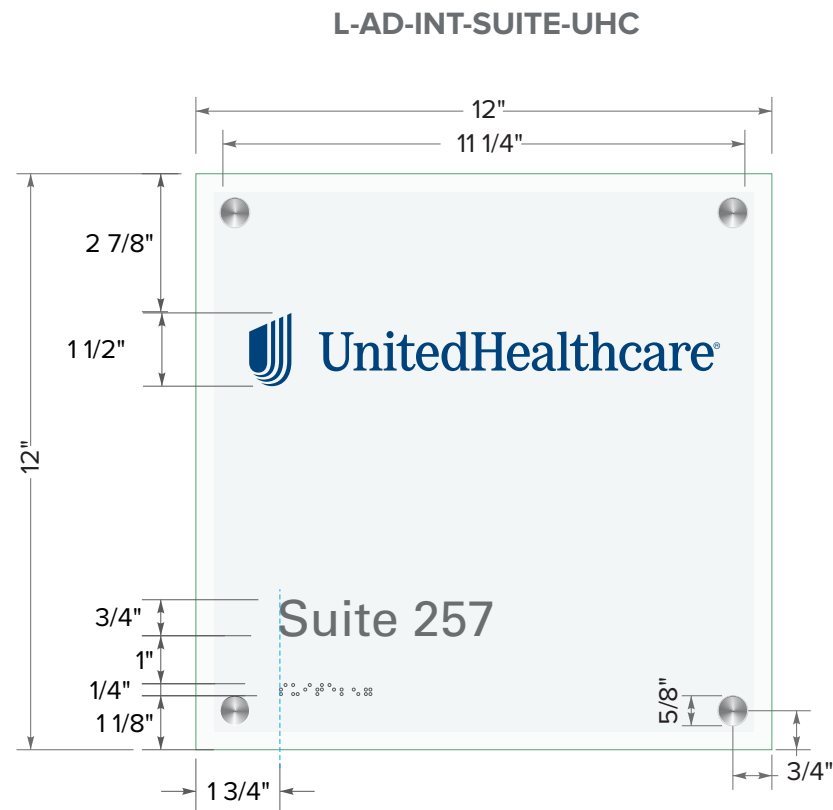

COLOR/ MATERIAL SPECIFICATIONS

PANEL: 1/4" thick clear acrylic with polished edges;
 ■ 2nd surface Avery #A5861 Etchmark vinyl

COPY: Surface applied vinyl logos per the following:
 ■ UHC / UHG Logo to be 3M #7725-37 Sapphire Blue vinyl

■ ROOM NUMBER: 1/32" raised tactile copy in Rowmark Charcoal Gray

FONT: Frutiger LT 55 Roman

BRaille: Grade II - Clear Braille Rasters

INSTALL: Install via aluminum standoffs and HD-S17 screws and HD-WB2 anchors 1/2" from wall surface.
 For glass, install via aluminum standoffs and VHB stood off 1/2" from glass surface.

Screw:
 HD-S17
 Anchor:
 HD-WB2

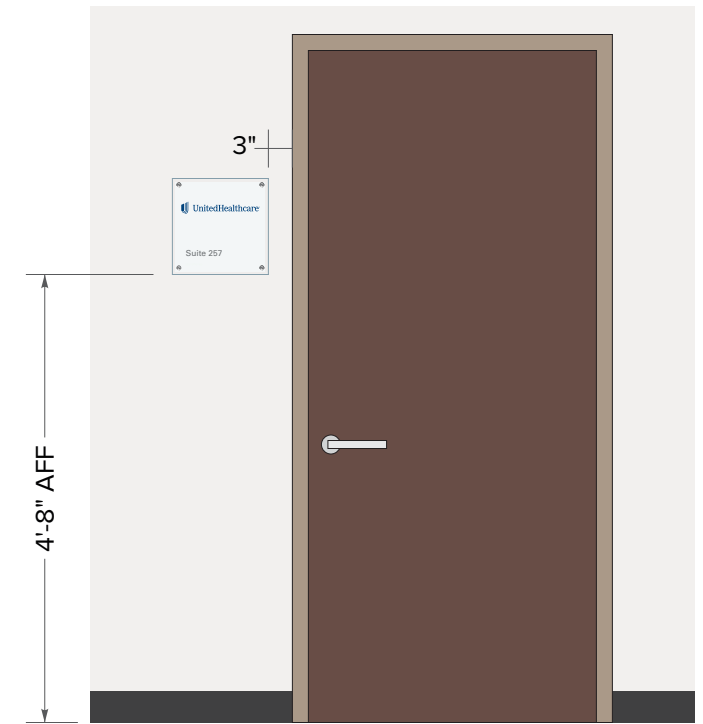

WALL MOUNT
 SCALE: 1/2" = 1'-0"

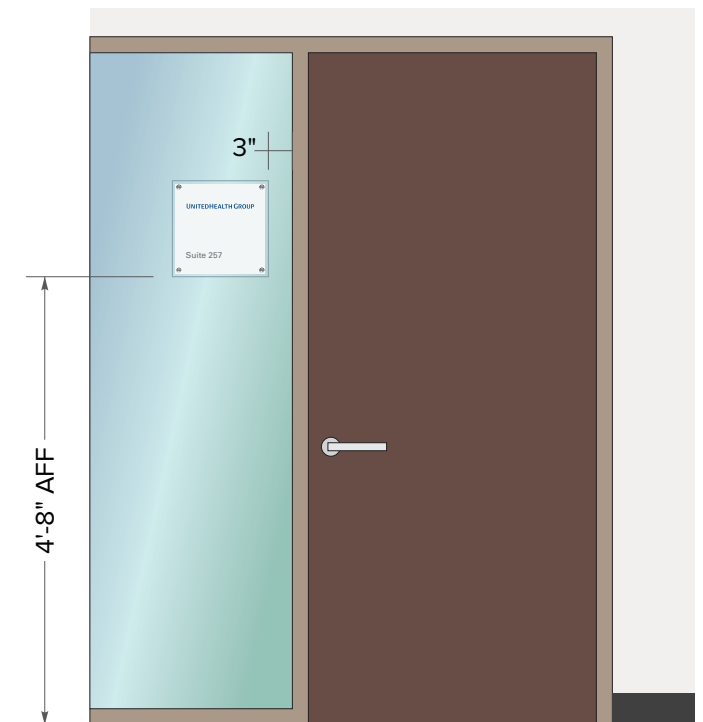
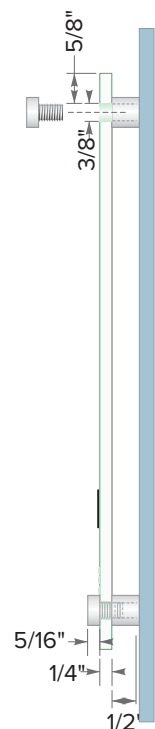
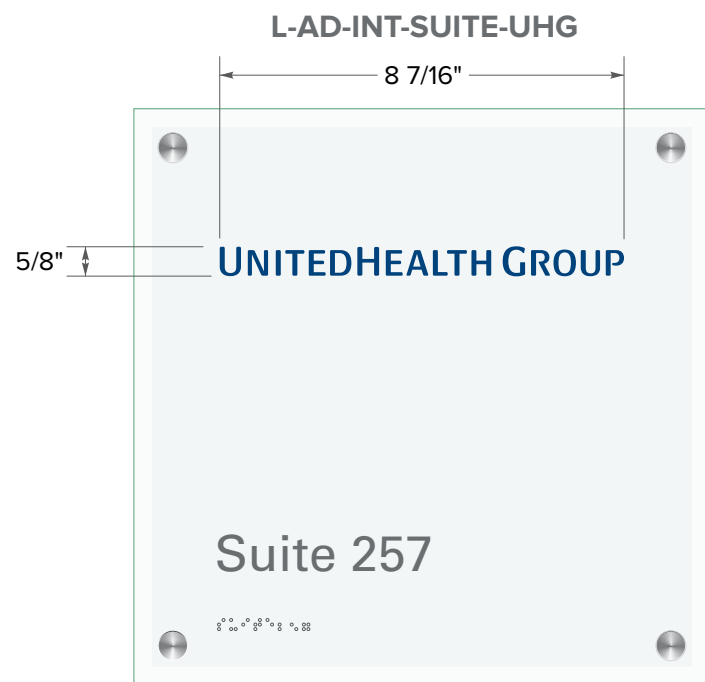

GLASS MOUNT
 SCALE: 1/2" = 1'-0"

SCALE | 1:4

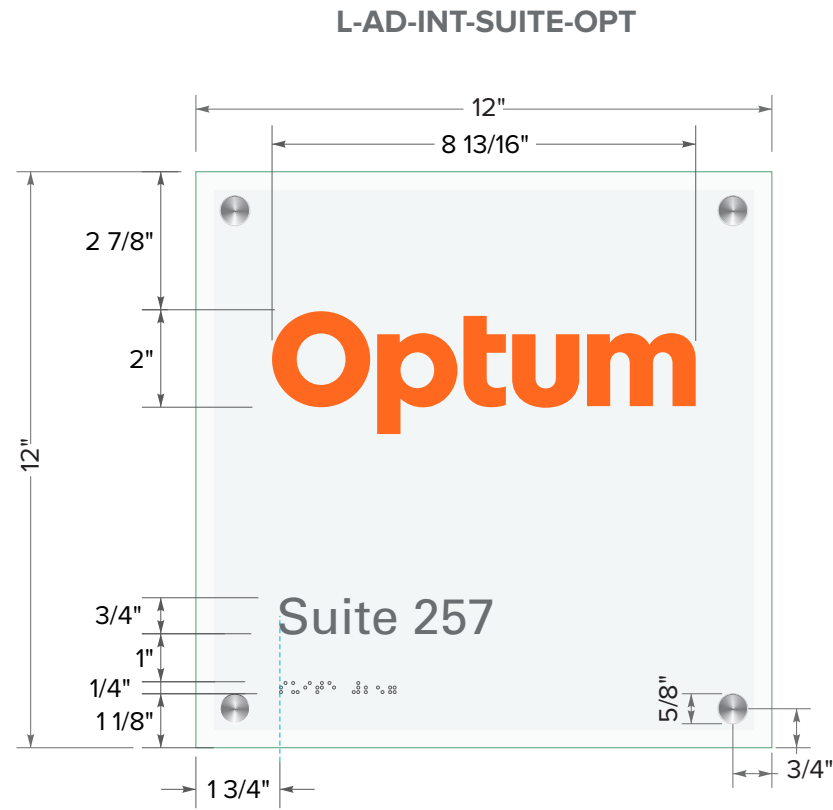

SCALE | 1:4

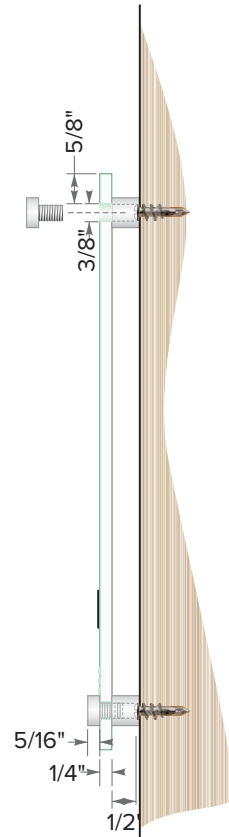

Screw:
HD-S17
Anchor:
HD-WB2

COLOR/ MATERIAL SPECIFICATIONS

PANEL: 1/4" thick clear acrylic with polished edges;
 2nd surface Avery #A5861 Etchmark vinyl

COPY: 3M #180mc-3289 Opaque Orange vinyl to first surface

ROOM NUMBER: 1/32" raised tactile copy in Rowmark Charcoal Gray

FONT: Frutiger LT 55 Roman

BRaille: Grade II - Clear Braille Rasters

INSTALL: Install via aluminum standoffs and HD-S17 screws and HD-WB2 anchors 1/2" from wall surface.
 For glass, install via aluminum standoffs and VHB stood off 1/2" from glass surface.

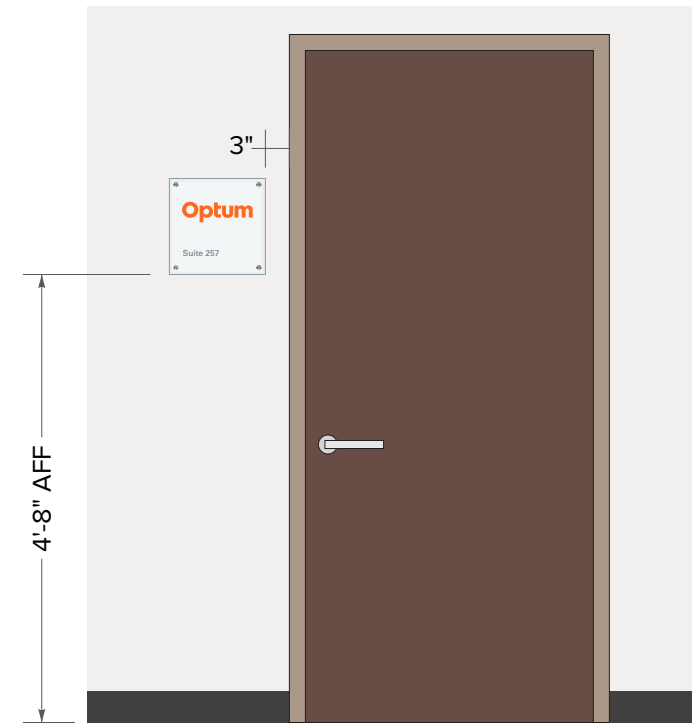
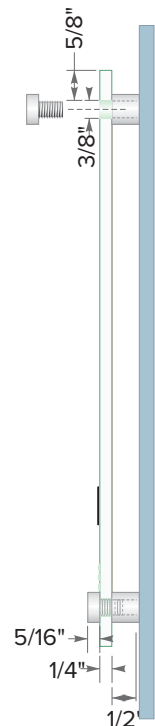

WALL MOUNT
SCALE: 1/2" = 1'-0"

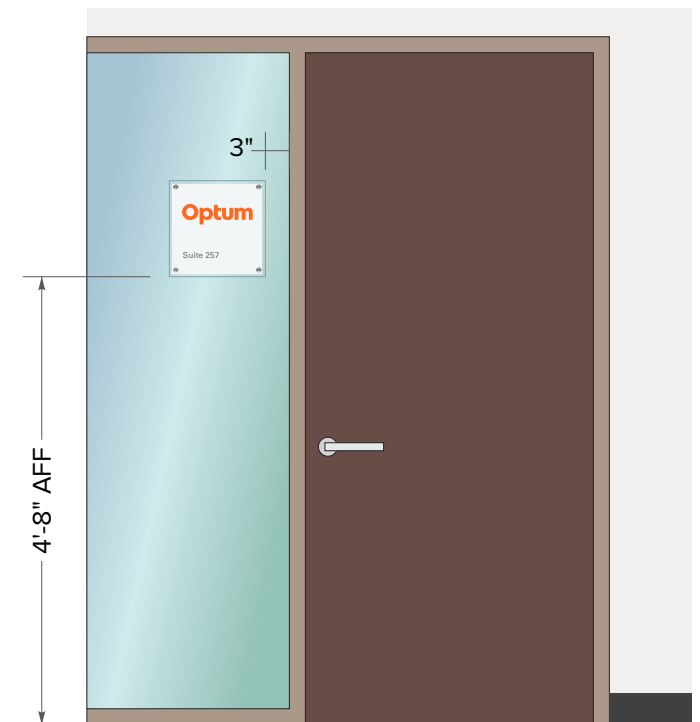

GLASS MOUNT
SCALE: 1/2" = 1'-0"

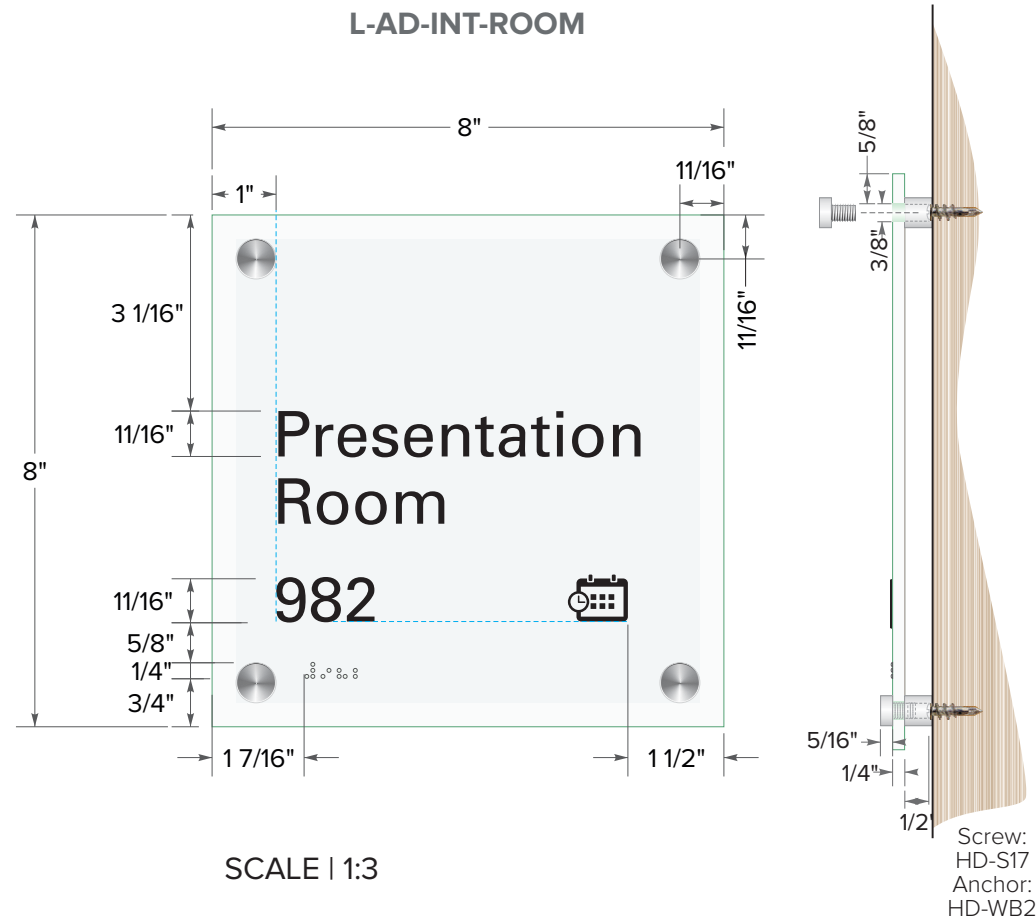

COLOR/ MATERIAL SPECIFICATIONS

- PANEL: 1/4" thick clear acrylic with polished edges;
 - 2nd surface Avery #A5861 Etchmark vinyl
- COPY: Avery Matte Black #A6080-0 vinyl to 1st surface
- ROOM NUMBER: 1/32" raised tactile copy in Rowmark Black
- FONT: Univers Lt Std Roman
- BRaille: Grade II - Clear Braille Rasters
- INSTALL: Install via aluminum standoffs and HD-S17 screws and HD-WB2 anchors 1/2" from wall surface. For glass, install via aluminum standoffs and VHB stood off 1/2" from glass surface.

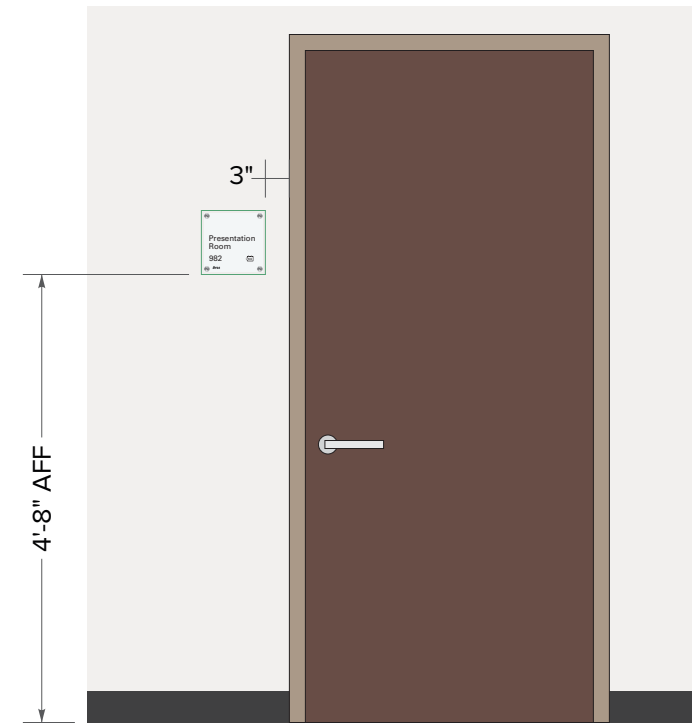

WALL MOUNT
SCALE: 1/2" = 1'-0"

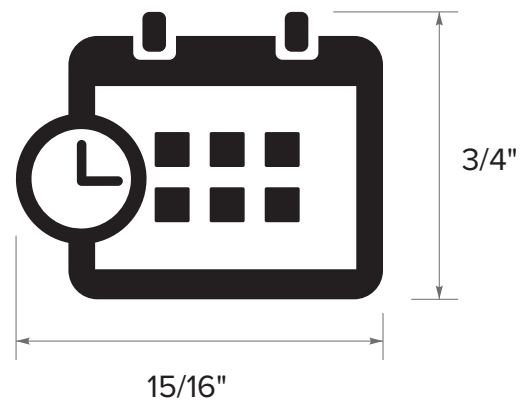

Use: Conference Rooms
Project Rooms
Multipurpose Rooms
Presentation Rooms
Telepresence Rooms

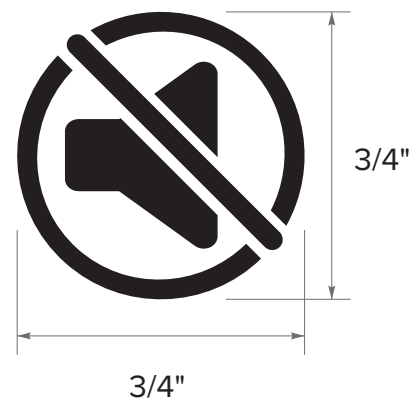

Use: Quiet Rooms

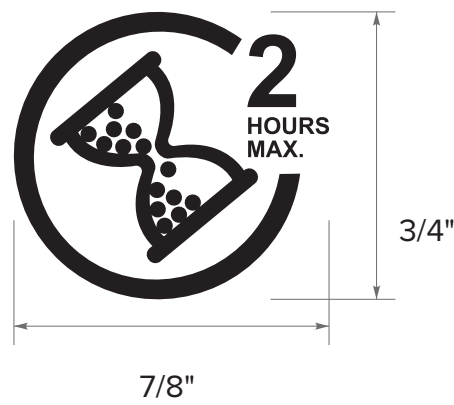

Use: Huddle Rooms
Media Rooms
Team Pods
Focus Rooms
1-on-1 Rooms

SCALE | 2:1

- VINYL ICONS: Avery Matte Black #A6080-0, applied 1st surface

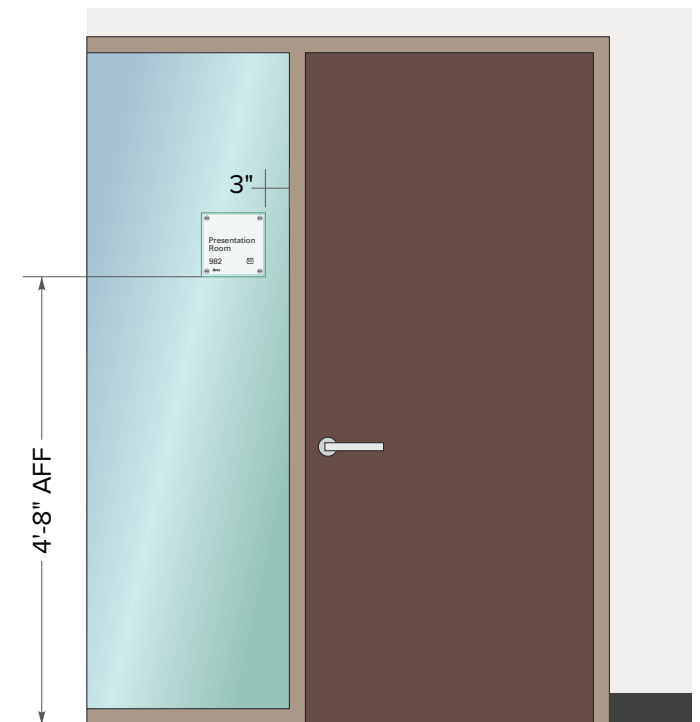

GLASS MOUNT
SCALE: 1/2" = 1'-0"

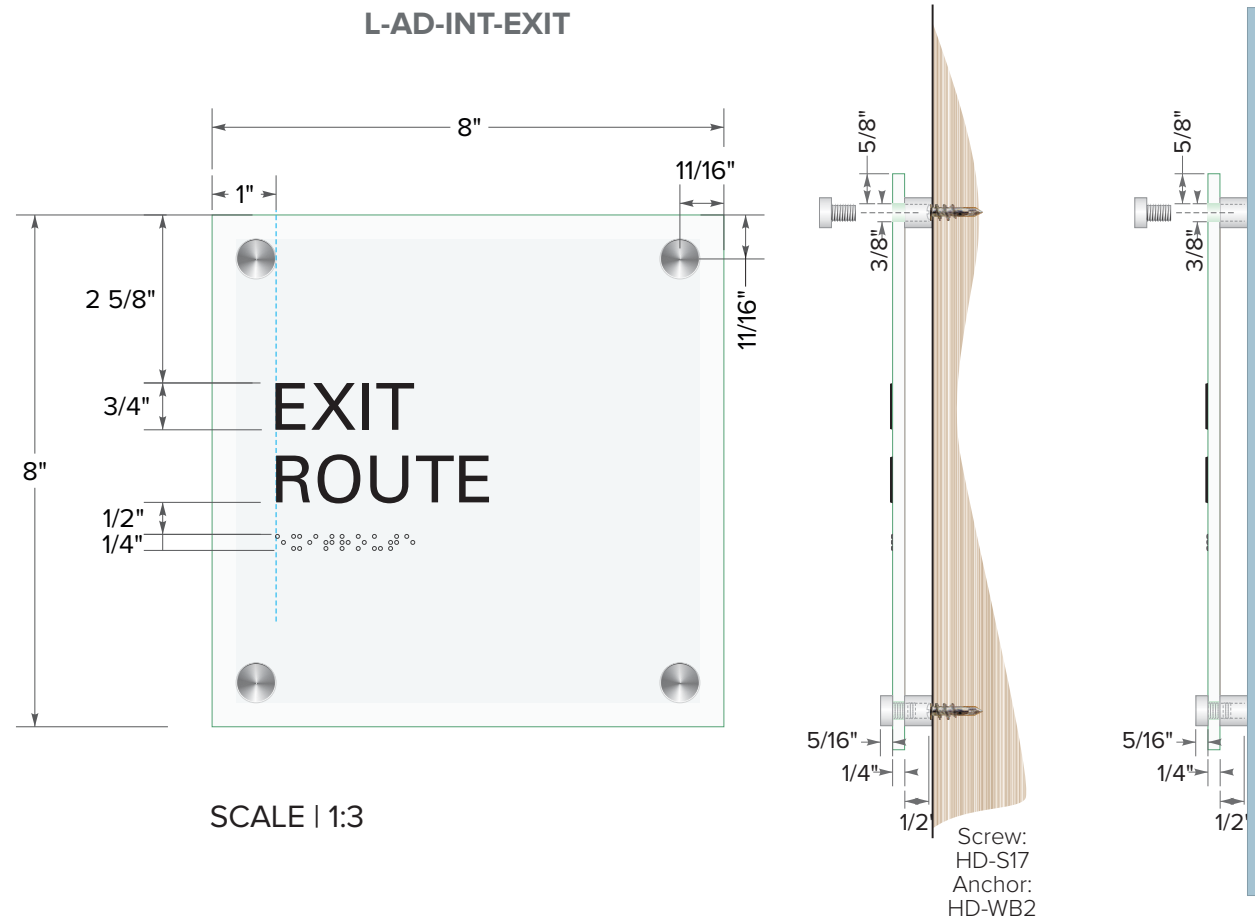

COLOR/ MATERIAL SPECIFICATIONS

PANEL: 1/4" thick clear acrylic with polished edges;
 □ 2nd surface Avery #A5861 Etchmark vinyl

■ COPY: 1/32" raised tactile copy in Rowmark Black

FONT: Univers Lt Std Roman

BRaille: Grade II - Clear Braille Rasters

INSTALL: Install via aluminum standoffs and HD-S17 screws and HD-WB2 anchors 1/2" from wall surface.
 For glass, install via aluminum standoffs and VHB stood off 1/2" from glass surface.

SCALE | 1:3

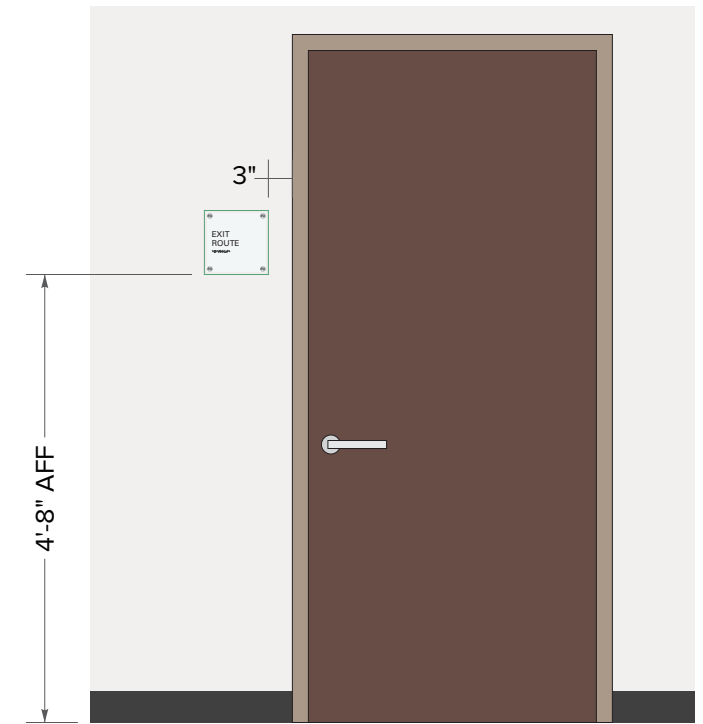

WALL MOUNT
SCALE: 1/2" = 1'-0"

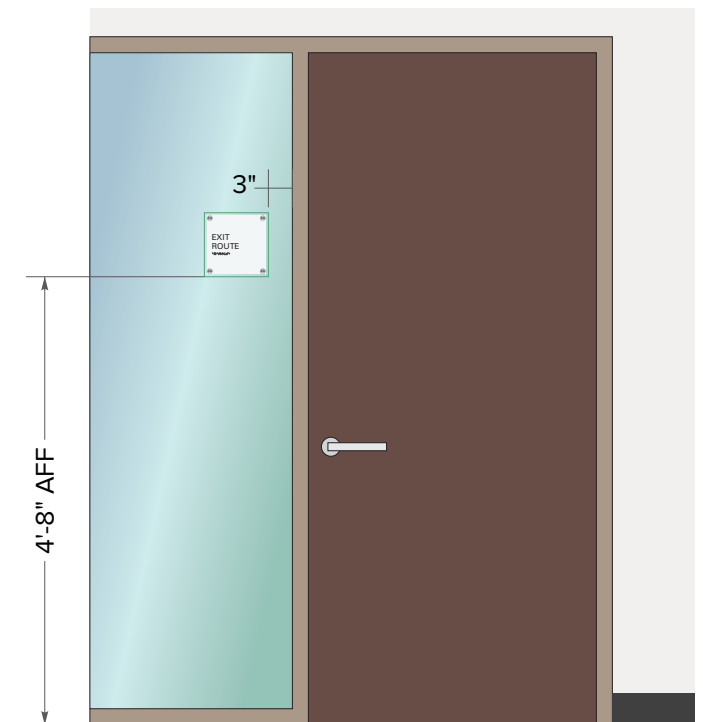

GLASS MOUNT
SCALE: 1/2" = 1'-0"

Alternate Layouts

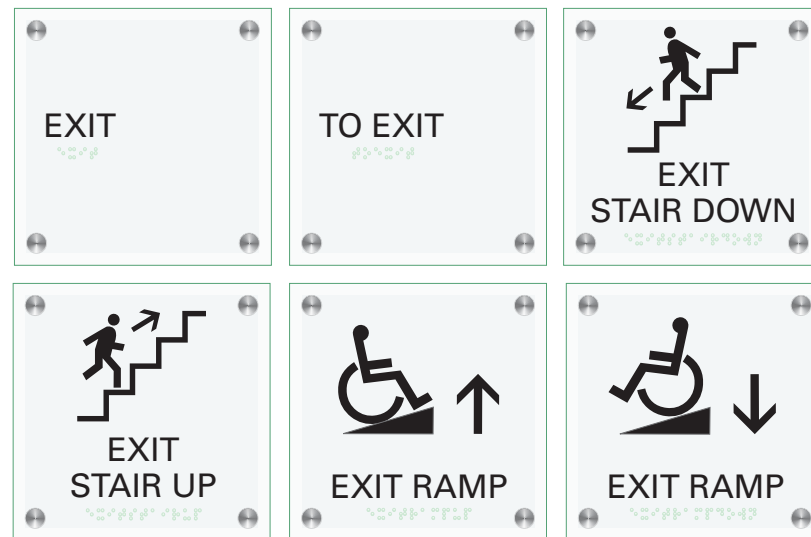

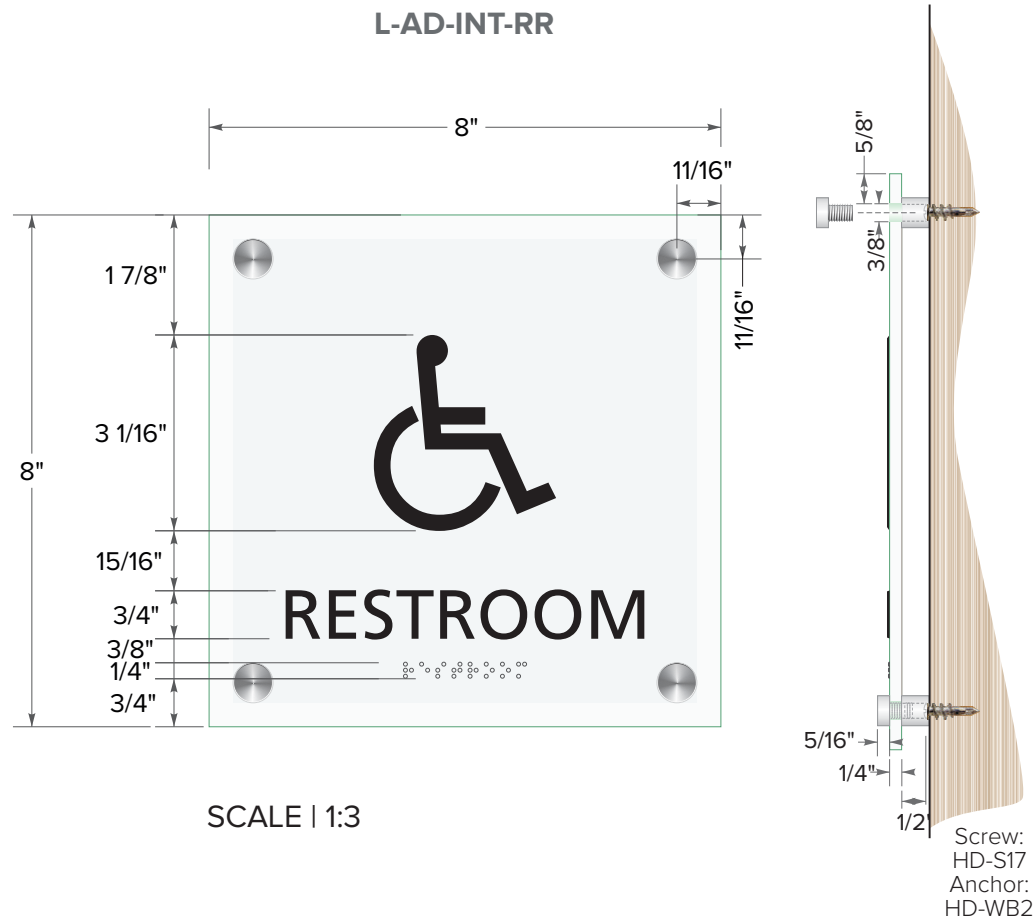

COLOR/ MATERIAL SPECIFICATIONS

PANEL: 1/4" thick clear acrylic with polished edges;
 □ 2nd surface Avery #A5861 Etchmark vinyl

■ COPY: 1/32" raised tactile copy in Rowmark Black

FONT: Univers Lt Std Roman

BRAILLE: Grade II - Clear Braille Rasters

INSTALL: Install via aluminum standoffs and HD-S17 screws and HD-WB2 anchors 1/2" from wall surface.
 For glass, install via aluminum standoffs and VHB stood off 1/2" from glass surface.

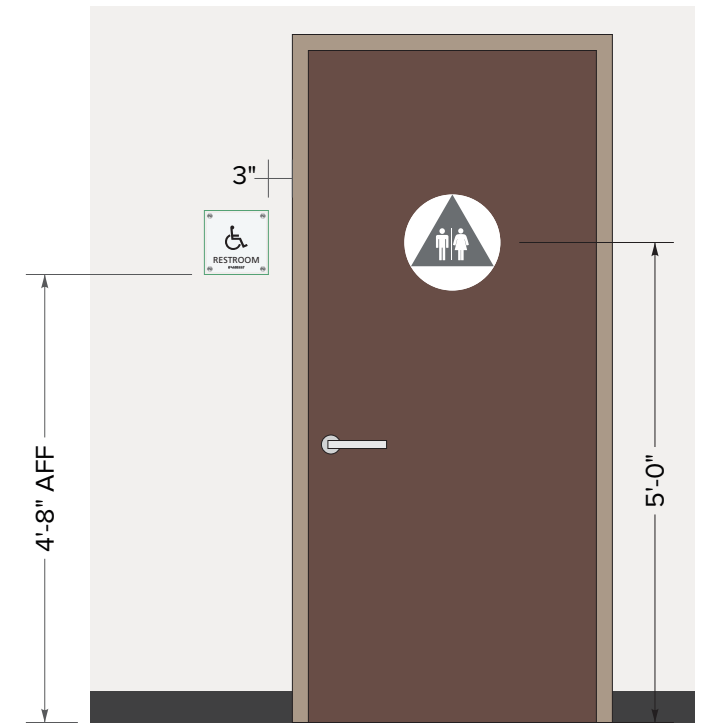

WALL MOUNT
 SCALE: 1/2" = 1'-0"

NOTE: Sites in California MUST include the door mounted acrylic plaque per state mandate.

Alternate Layouts



IMPORTANT:

The sign with the wheelchair symbol should be used to replace existing signage that already indicates that the room is ADA accessible. If the existing signage does not indicate that the restroom is ADA accessible, the signage without the wheelchair symbol should be used.

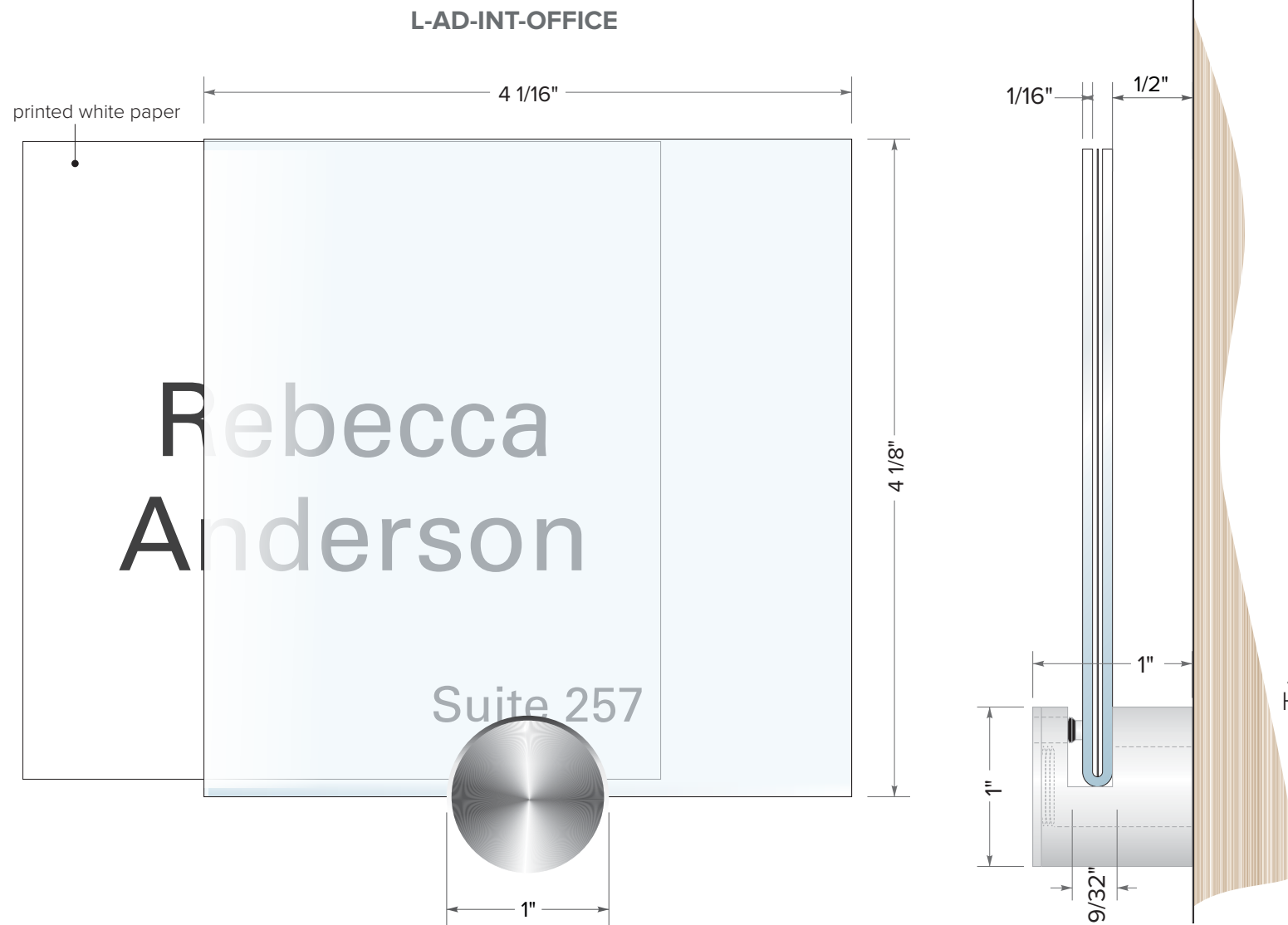

COLOR/ MATERIAL SPECIFICATIONS

PANEL: 1/16" clear polycarbonate panel, heated formed to shape

FONT: Univers Lt Std Roman

INSTALL: Install via aluminum standoffs and HD-S17 screws and HD-WB2 anchors 1/2" from wall surface.
Glass: Install via aluminum standoffs and VHB stood off 1/2" from glass.

Screw: HD-S17
Anchor: HD-WB2

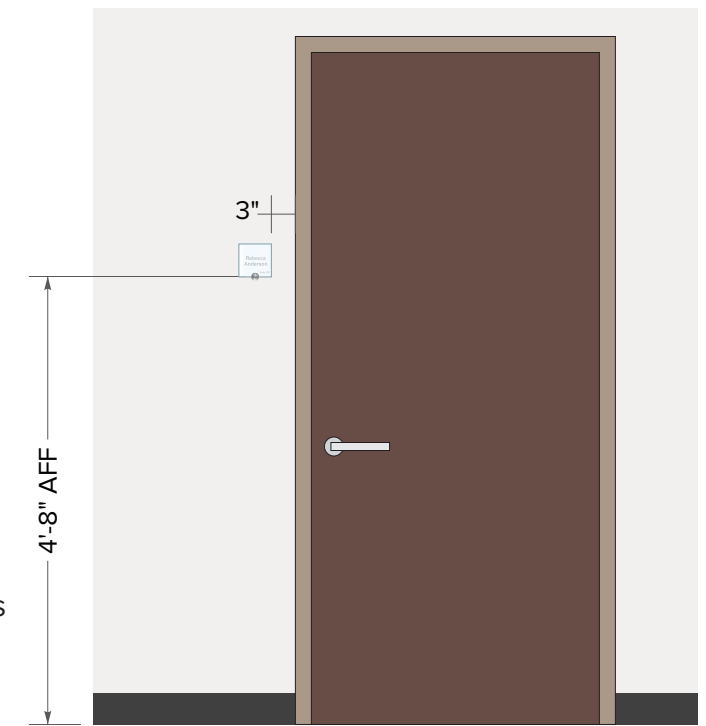

WALL MOUNT
SCALE: 1/2" = 1'-0"

INSERT LAYOUTS

L-AD-INT-OFFICE-OPT

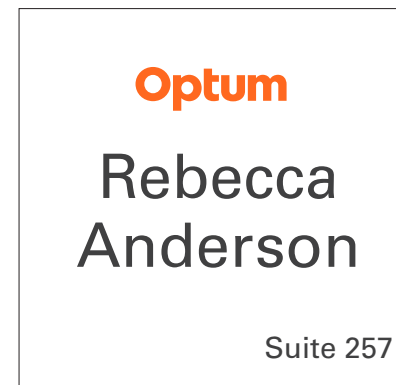

L-AD-INT-OFFICE-UHG



L-AD-INT-OFFICE-UHC



COPY: Paper insert with laser printed copy matching:
■ UHC / UHG - to match PMS 288C
■ Optum - to match PMS 165C

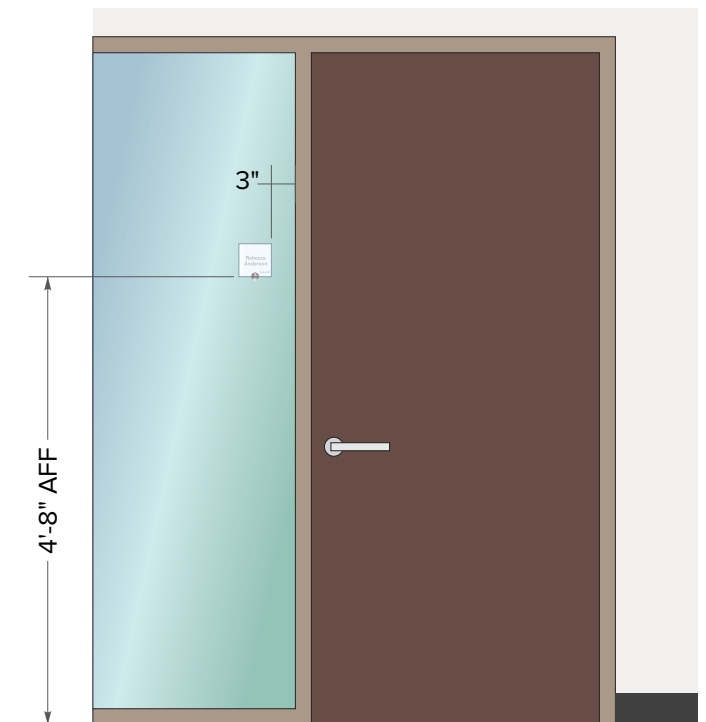

GLASS MOUNT
SCALE: 1/2" = 1'-0"

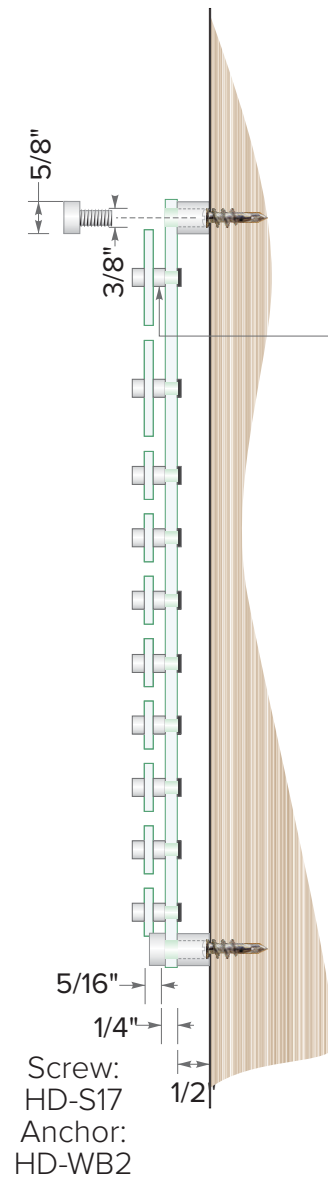
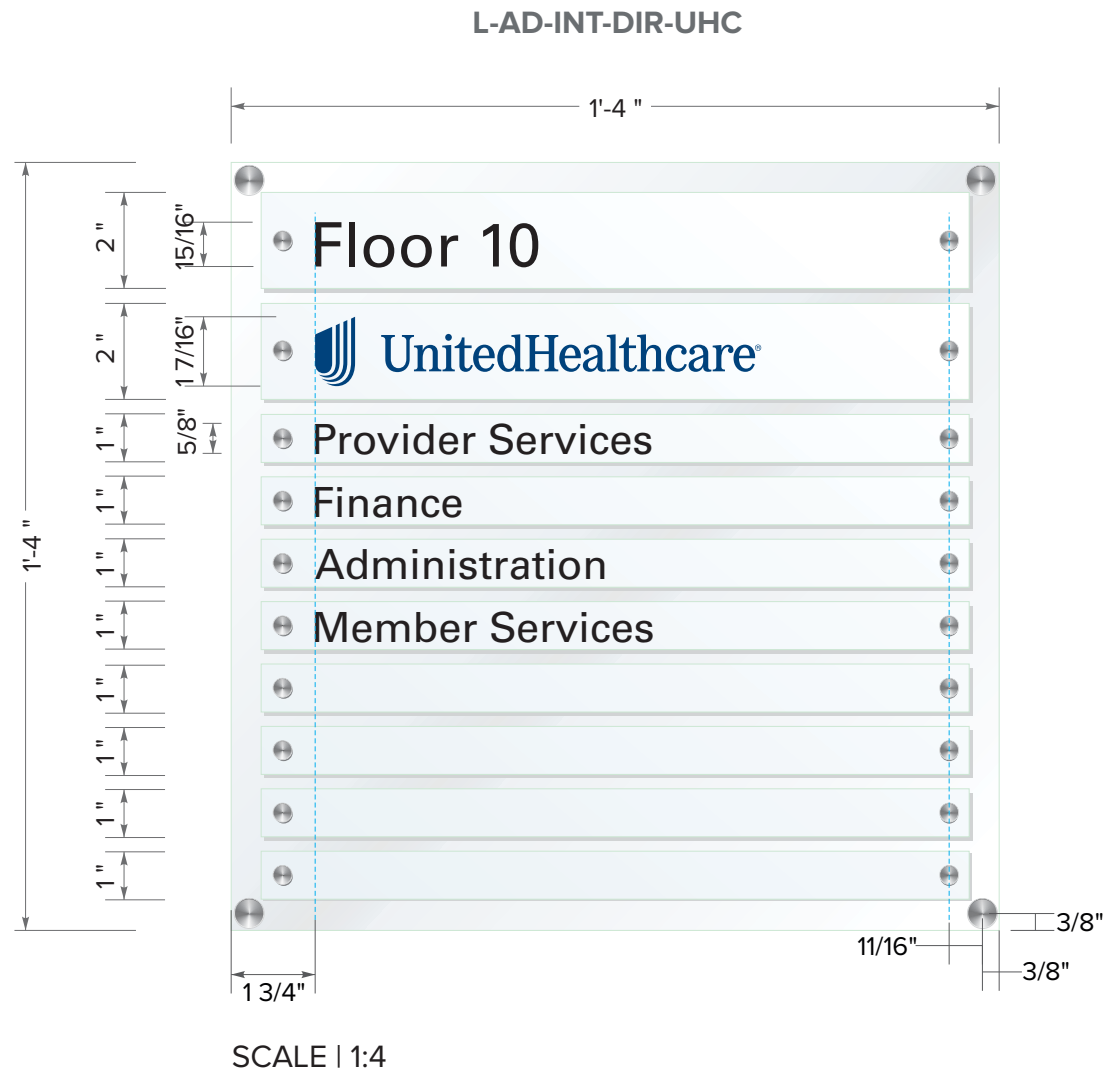

- (20) Gyford SO-CAP7 Caps
- (20) Gyford SO-025 Barrels
- (20) Gyford HD-STC4 Socket Head Cap Screws
- (FOR PANEL SHOWN)

COLOR/ MATERIAL SPECIFICATIONS

PANEL: 1/4" clear acrylic with polished edges
 TENANT PANELS: 3/16" clear acrylic with polished edges stood off backer by 1/4" using 3/8" diameter Cap Gyford stand off system w/ 1/2" barrel

- LOGOS: Optum - 3M #180mc-3289 Opaque Orange; UHC / UHG -3M #7725-37 Sapphire Blue vinyl
- COPY: 3M #7725-22 Matte Black vinyl

FONT: Univers Lt Std Roman

INSTALL: Install with 5/8" diameter Cap Gyford standoff system with 5/8" barrel; stud mounted to wall surface via HD-S17 screws and HD-WB2 wall anchors

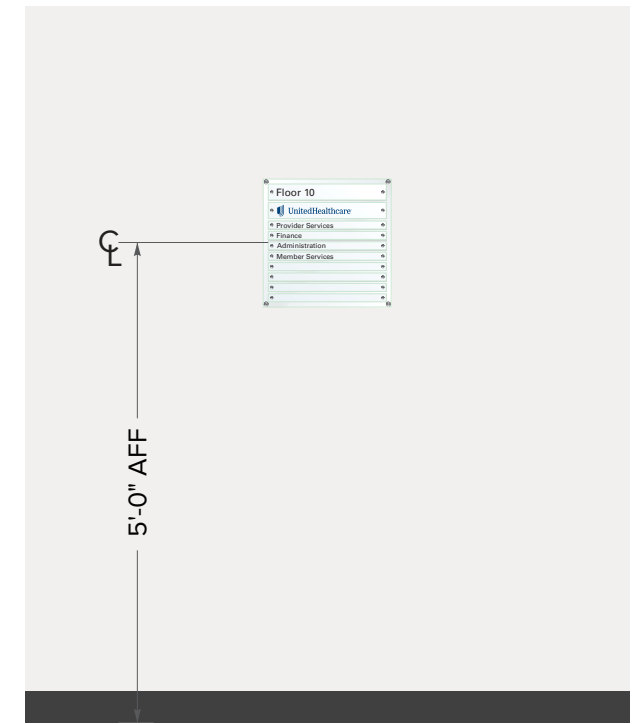

WALL MOUNT
SCALE: 1/2" = 1'-0"

L-AD-INT-DIR-OPT

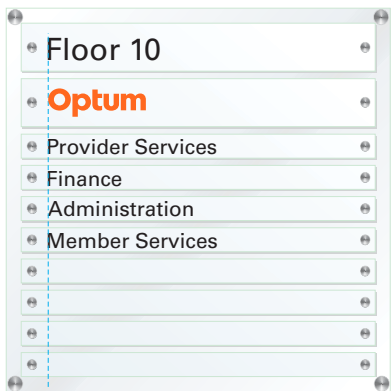

L-AD-INT-DIR-UHG

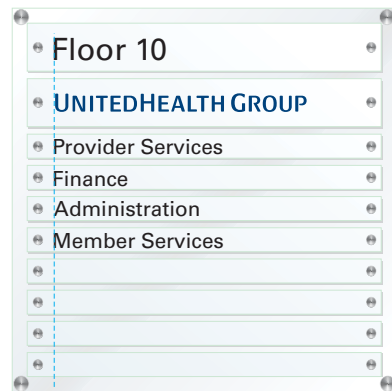

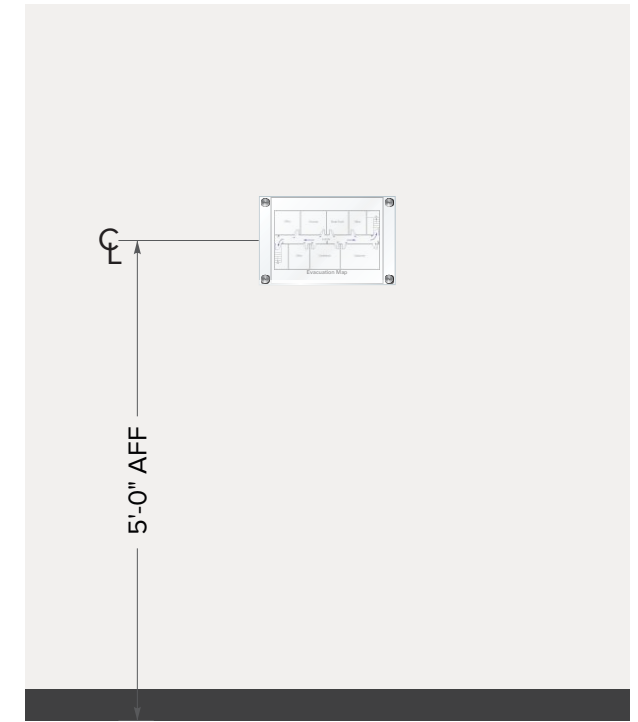
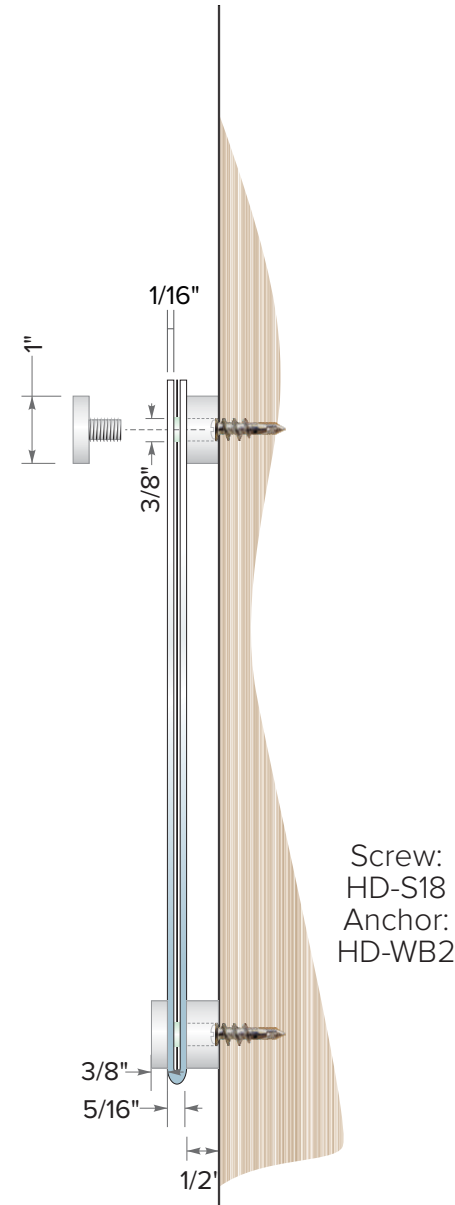
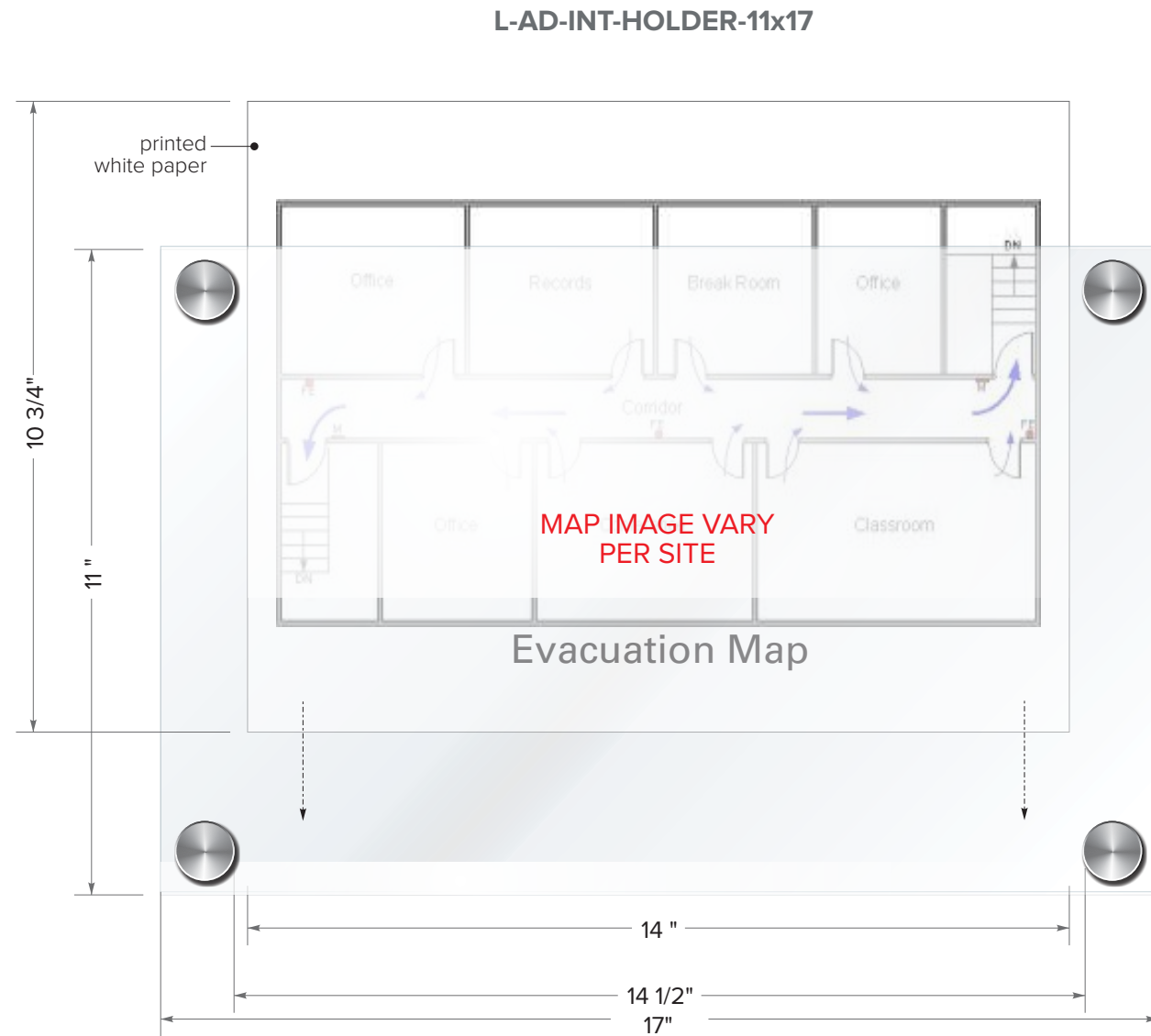

WALL MOUNT
SCALE: 1/2" = 1'-0"

COLOR/ MATERIAL SPECIFICATIONS

PANEL: 1/16" clear polycarbonate panel, heated formed to shape

COPY: Paper insert with laser printed copy

INSTALL: Install with 1" diameter Cap Gyford standoff system with 1/2" barrel; stud mounted into wall surface via HD-S17 screws and HD-WB2 wall anchors

SCALE | 1:3

COLOR/ MATERIAL SPECIFICATIONS

- GRAPHICS: Surface applied 3M #7125-120 Satin Aluminum vinyl decal with
- 3M #7725-12 Opaque Black vinyl copy & symbol

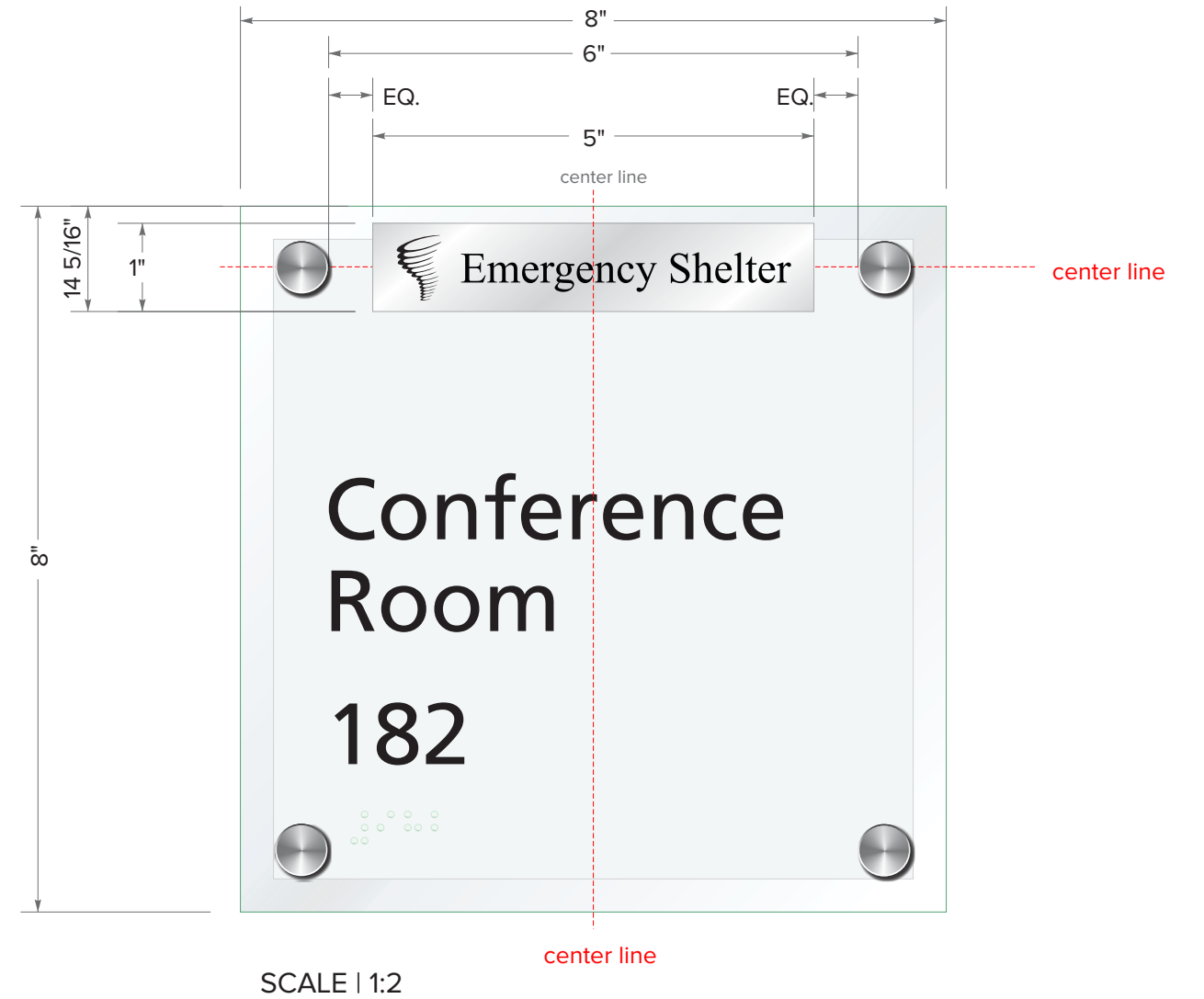
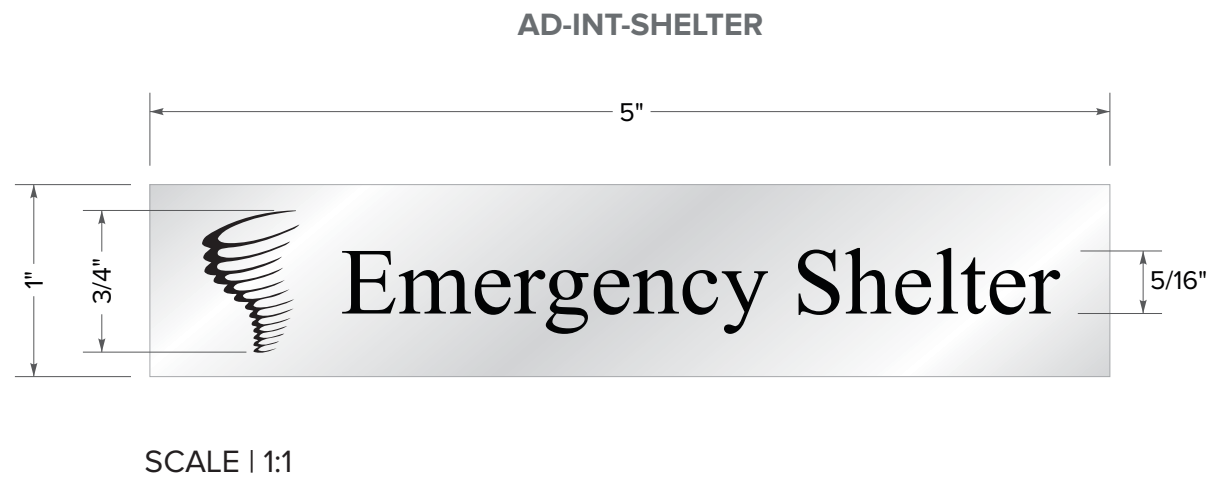

Privacy Graphic approved applications:
 Huddle Rooms / Conference Rooms / Offices
 3M Lausanne Films (Applied to outside of window area of rooms)



Ticker & Logo: 3M Frosted Crystal 7725SE-324

Bands: 3M Lausanne Film #SH2EMLA

*Install Window striping in 7'-5 1/4" (2266 mm) pieces (repeating pattern) install level following same plane as the door vinyl. If more windows are available continue installing the 7'-5 1/4" (2266 mm) repeating pattern until visible opening in complete.

seams must have 1/8" (6 mm) gap as rest of pattern

L-AD-INT-FILM-OPT-2

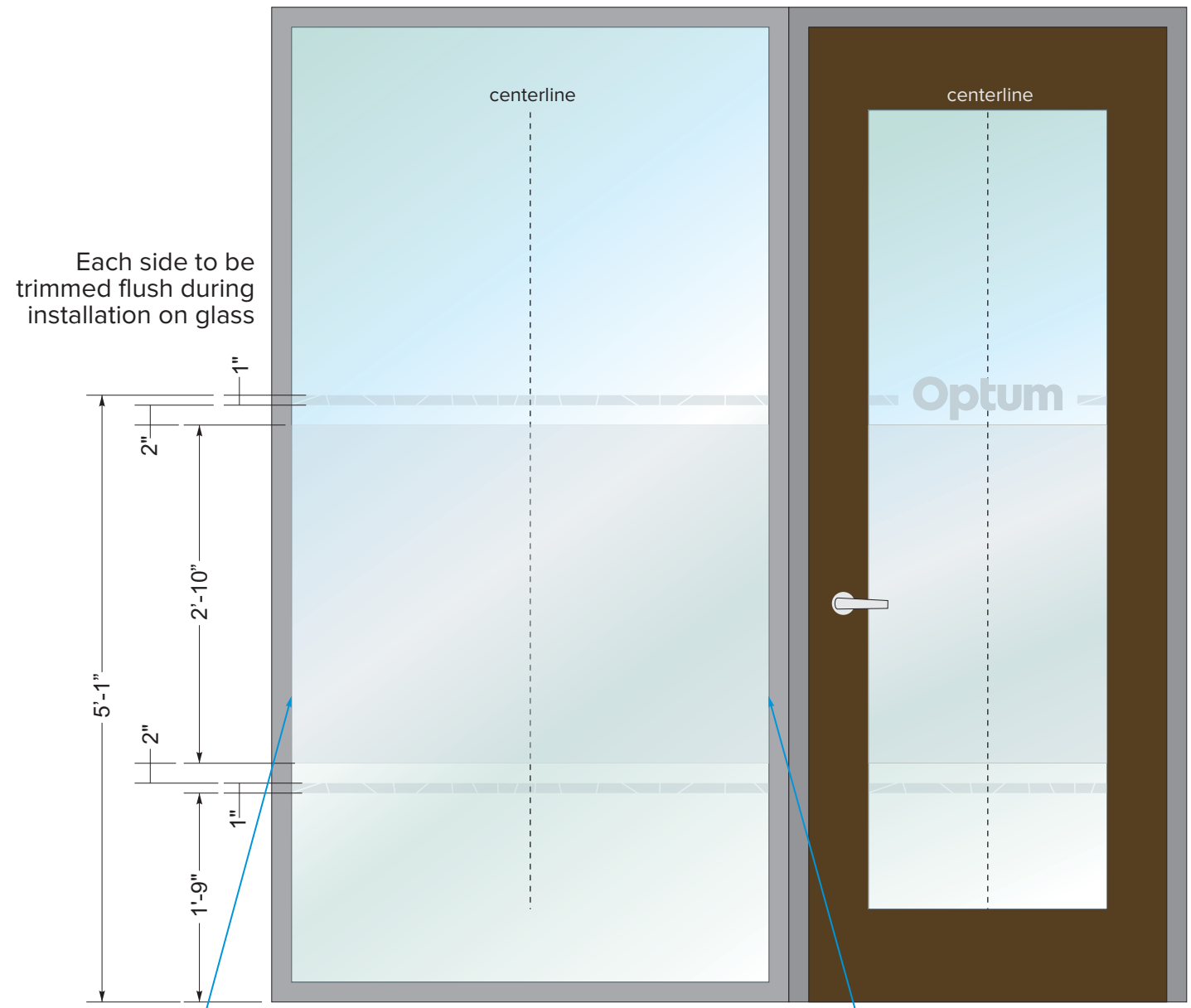

Important Note:
 Solid 2'-10" (34 mm) Lausanne stripe should never have seams in the middle of visible opening of glass. Seams should land on end of glass panels only.

LOGO DETAILS:

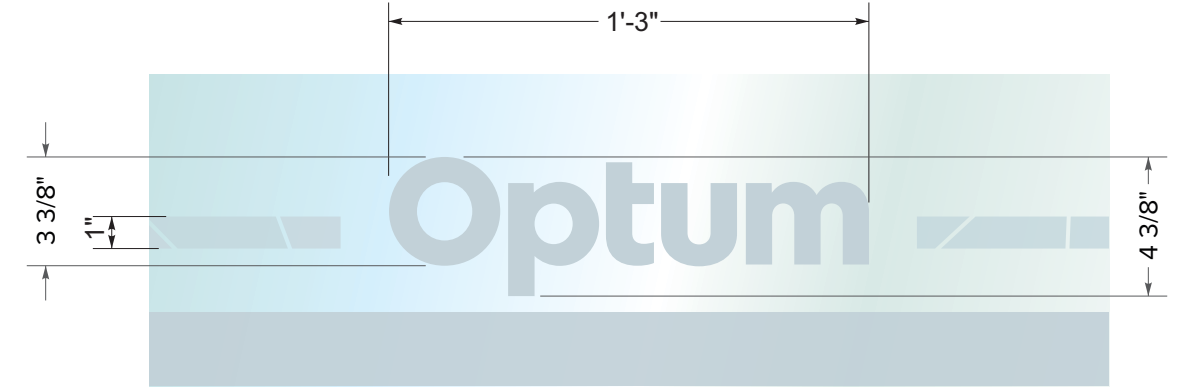

scale | 1:6

Installation Instructions:

Install entire graphic at 5'-1" from finished floor to top of Ticker Graphic. Graphic is then trimmed to exact visual opening. (All seams at window panel ends need to be cut and tucked with squeegee).

Special Note:

No logo is installed on windows.

scale: 3/4" = 1'-0"

Ticker Graphic approved applications:
 Huddle Rooms / Conference Rooms / Offices
 3M Lausanne Film (Applied to outside of window area of rooms)

Installation Instructions:
 Install entire graphic at 4'-1" from finished floor to bottom of rule line.
 Graphic is then trimmed to the exact visual opening.

Special Note:
 No logo is installed on windows or doors
 that are under 24" wide.

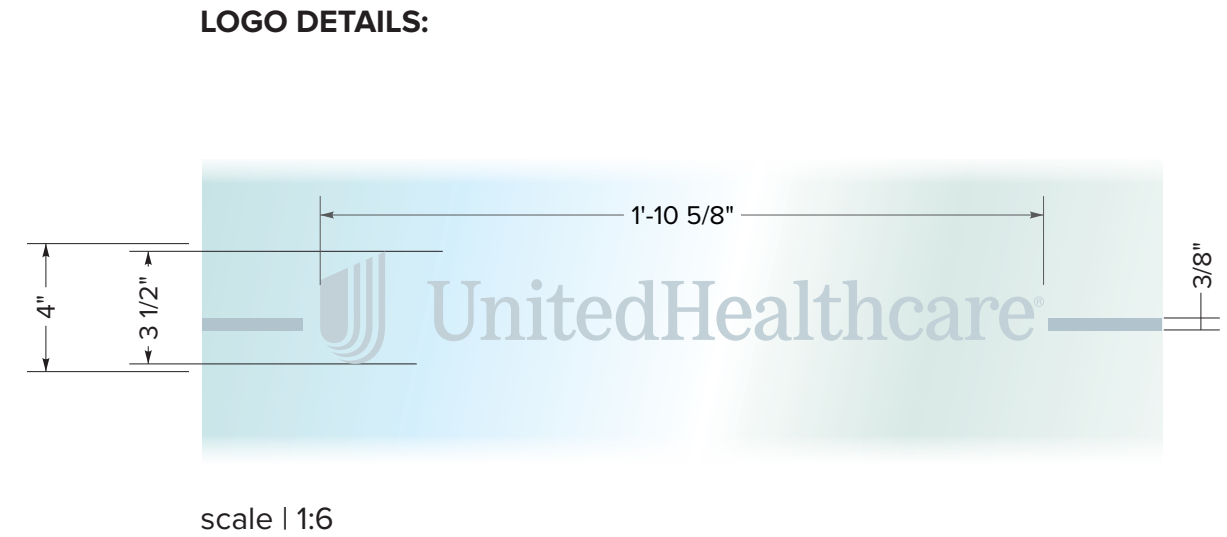
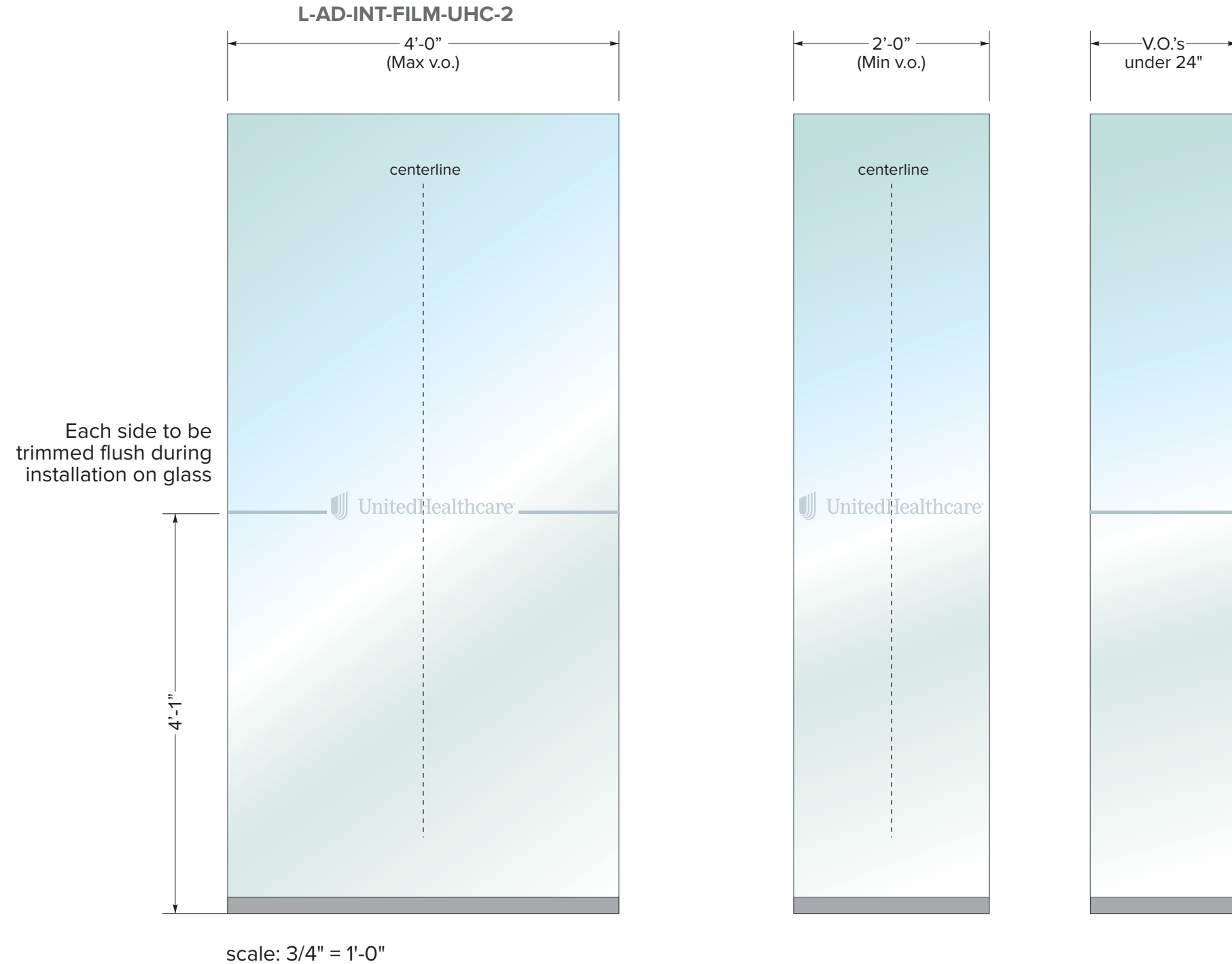
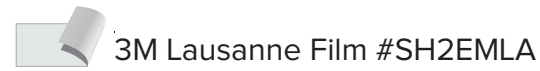

Privacy Graphic approved applications:
 Huddle Rooms / Conference Rooms / Offices
 3M Lausanne Film (Applied to outside of window area of rooms)

Installation Instructions:
 Install entire graphic at 6'-0" from finished floor to top of Privacy Graphic.
 Graphic is then trimmed to the exact visual opening.

Special Note:
 No logo is installed on windows or doors
 that are under 24" wide.

 3M Lausanne Film #SH2EMLA

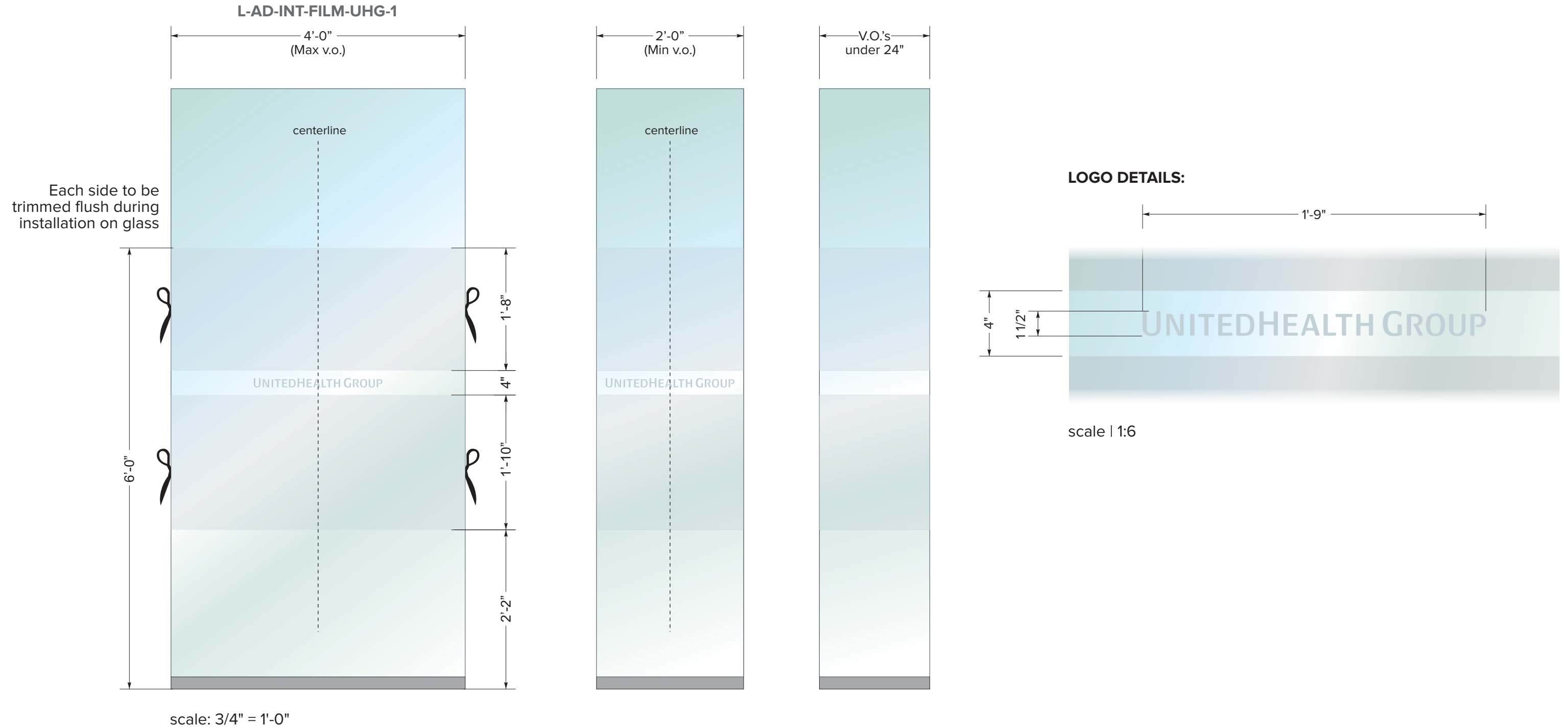

Ticker Graphic approved applications:
 Huddle Rooms / Conference Rooms / Offices
 3M Lausanne Film (Applied to outside of window area of rooms)

Installation Instructions:
 Install entire graphic at 4'-1" from finished floor to bottom of rule line.
 Graphic is then trimmed to the exact visual opening.

Special Note:
 No logo is installed on windows or doors
 that are under 24" wide.

 3M Lausanne Film #SH2EMLA

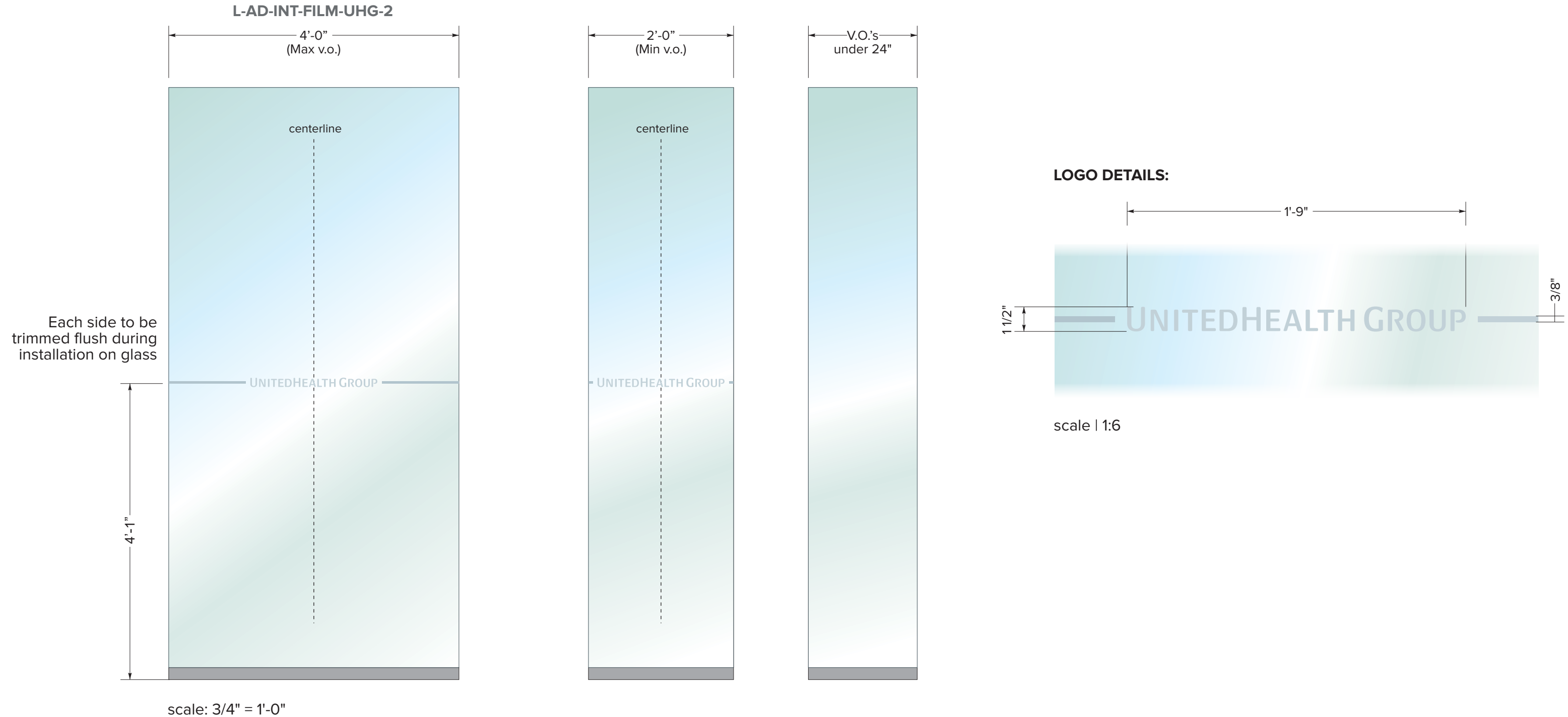

Values Graphic approved applications:
 Huddle Rooms / Conference Rooms / Offices
 3M Lausanne Film (Applied to outside of window area of rooms)

Installation Instructions:
 Install entire graphic at 6'-0" from finished floor to top of Privacy Graphic.
 Graphic is then trimmed to the exact visual opening.

Special Note:
 One Values per glass pane.
 No logo is installed on windows or doors that are under 24" wide.

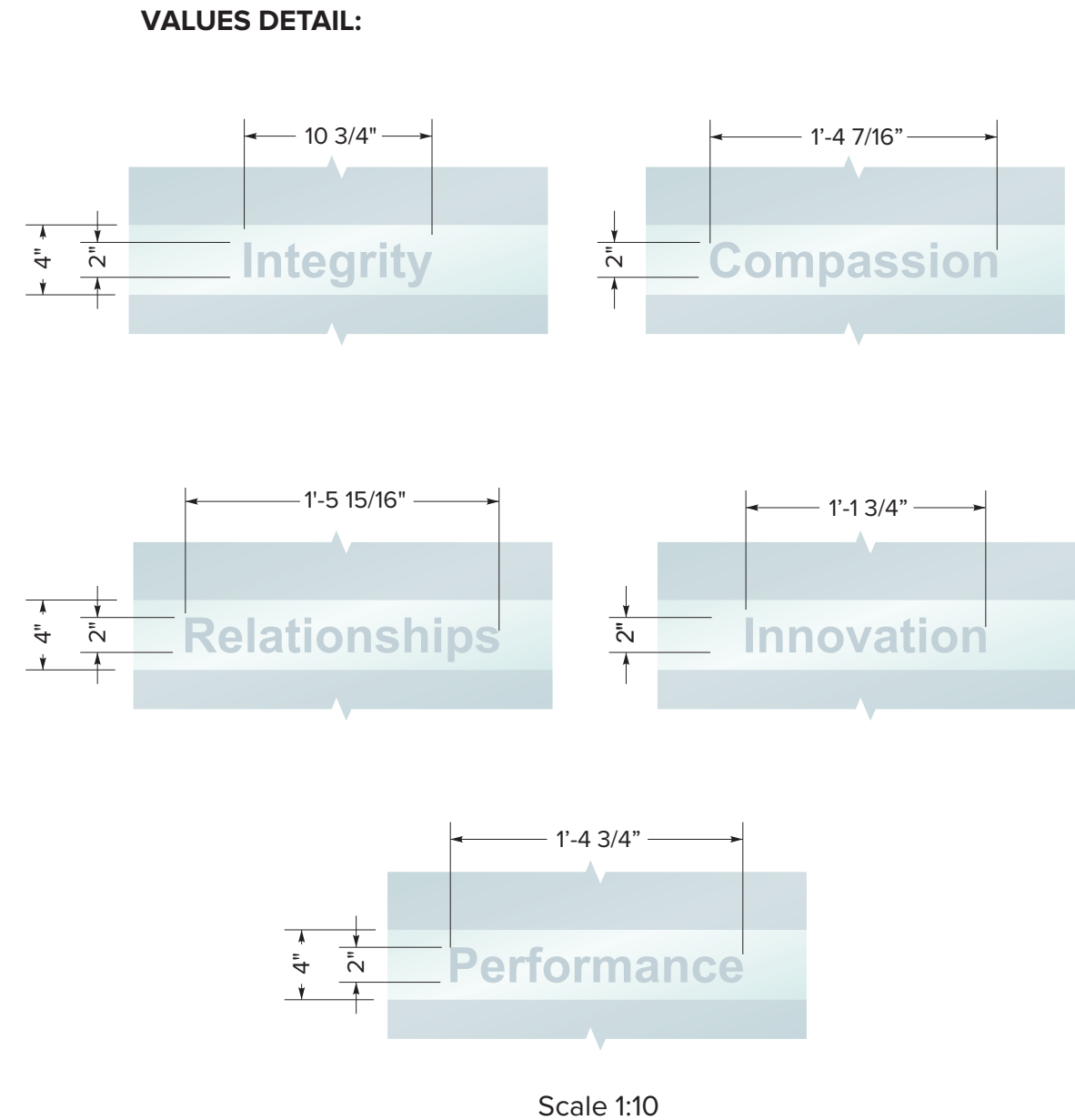
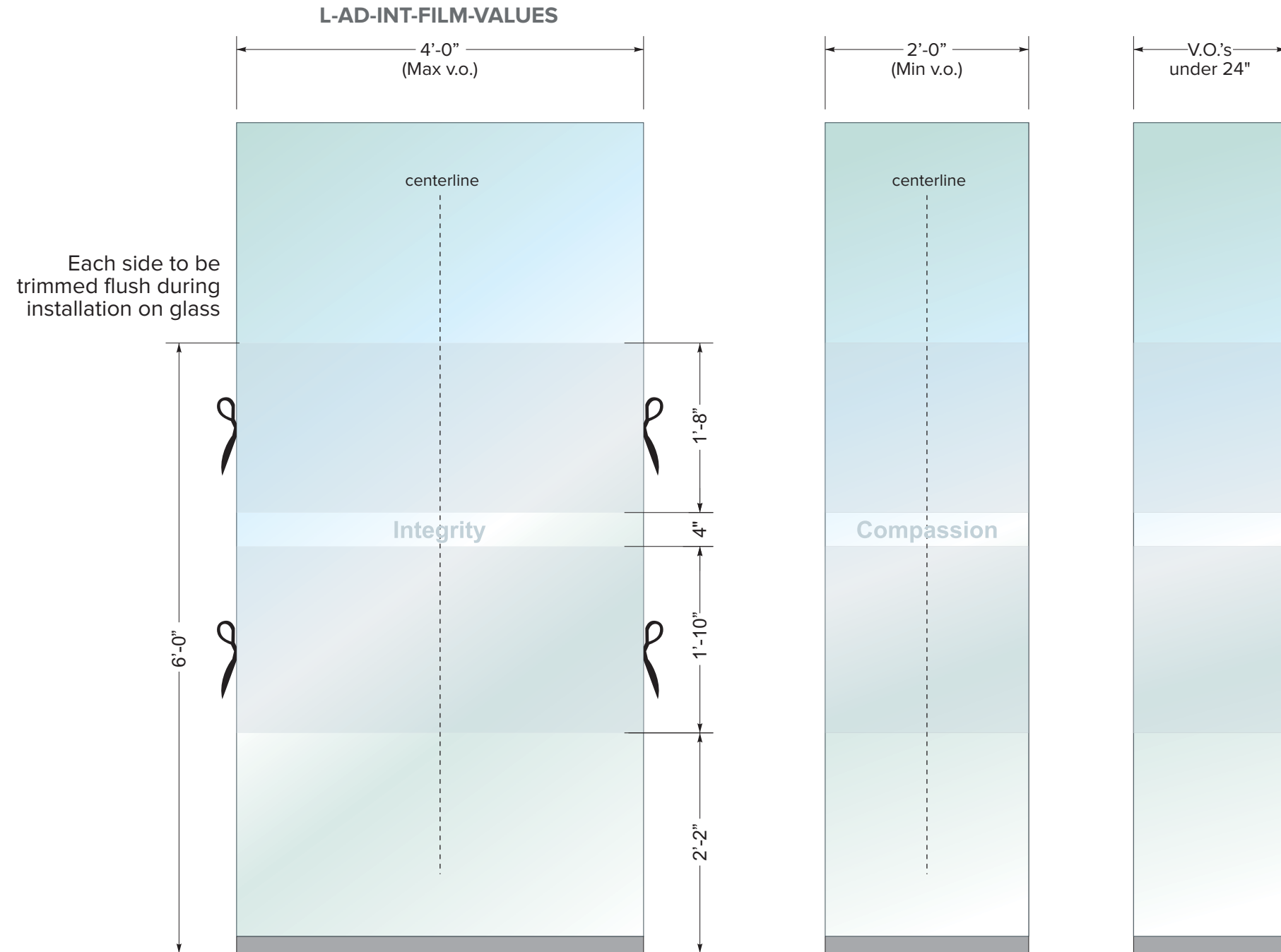

scale: 3/4" = 1'-0"



Values Graphic approved applications:
Huddle Rooms / Conference Rooms / Offices
3M Lausanne Film (Applied to outside of window area of rooms)

Installation Instructions:
Install entire graphic at 6'-0" from finished floor to top of Privacy Graphic.
Graphic is then trimmed to the exact visual opening.

Special Note:
Values must repeat in the following order from left to right:
Integrity, Compassion, Relationships, Innovation, and Performance.
One Values per glass pane. No logo is installed on windows or doors that are under 24" wide.



Proper Order of Sequence from Left to Right

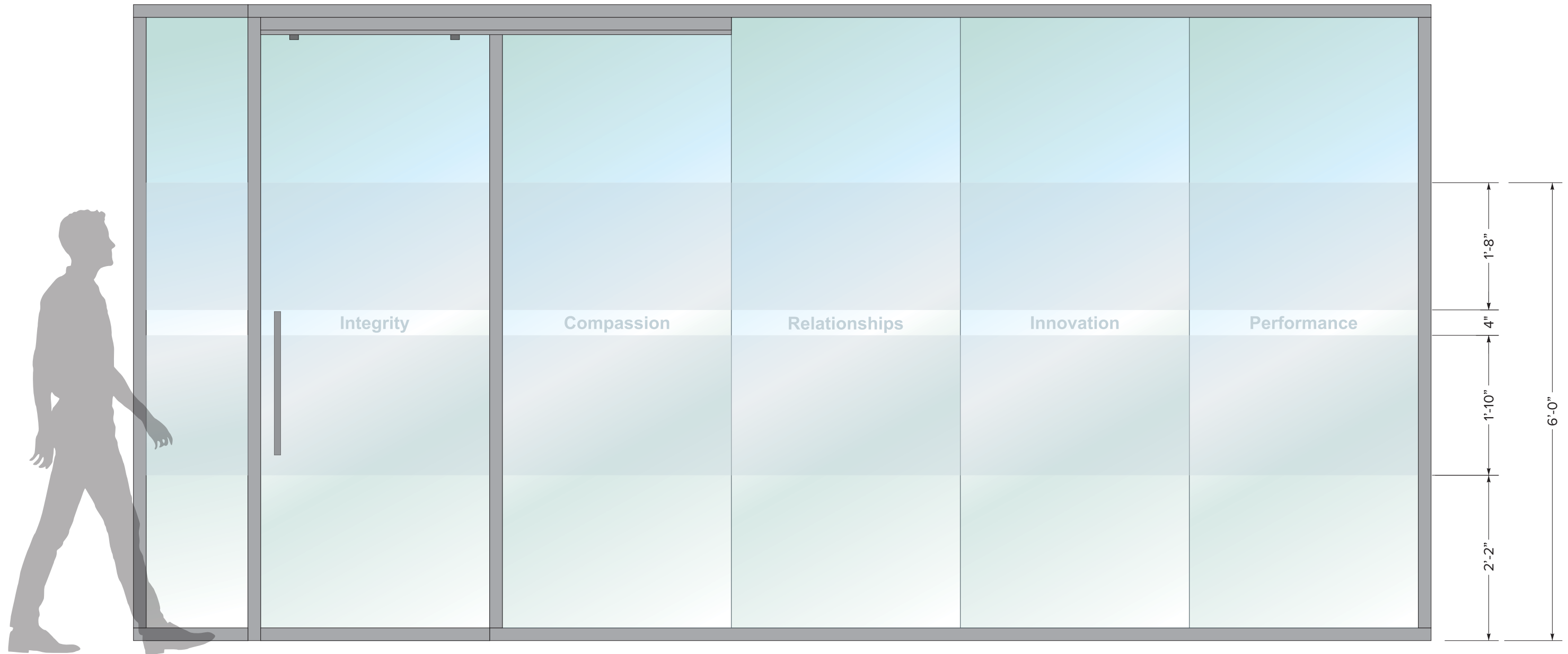

scale: 3/4" = 1'-0"

Version Update 1.0.1: 5-10-2023

Page #33-35 - Updated Optum logo to new logo on privacy films
Page #27 - Added notations for icons' room use

Version Update 1.0.2: 6-30-2023

Page #5 - Updated name placeholder and added insert template
Page #6 - Added to book.
Page #7 - Added to book.
Updated UnitedHealthcare logo throughout all pages

Version Update 1.0.3: 8-08-2032

Page #4 - Added new "click to join" icon.

Version Update 1.0.4: 9-15-2023

Page #18 - Added new Mother's Room Privacy Film

Version Update 1.0.5: 9-27-2023

Page #23 - Added new Compost or Organics Decal
Page #24 - Added new circular waste/recycle decals

Version Update 1.0.6: 12-21-2023

Page #8 - Updated room name list

Version Update 1.0.7: 3-7-2024

Page #4-7 - Added Suite Entrance Door Vinyl Options
Page #13 - Removed branded workstation holder options
Page #27 - 32 - Added Waste Signage
Page #34 & 35 - Added FCO Signage